



# P R O A R H

**Proarh mateković d.o.o.**  
za arhitektonsko projektiranje

Kneza Mislava 15,  
Zagreb, 10000, Croatia  
t. +385 1 46 36 015  
t. +385 1 46 36 002  
f. +385 1 45 52 878  
e. proarh@proarh.hr  
www.proarh.hr

Investitor :	Virovitičko-podravska županija Trg Ljudevita Patačića 1, 33000 Virovitica OIB: 93362201007
Građevina/ zahvat u prostoru :	Centar za kulturu zdravlja - Rekonstrukcija starog dvorca Janković
Lokacija :	Cabuna, k.č.br. 607 k.o. Cabuna
Faza projekta :	<b>IZVEDBENI PROJEKT</b> <b>MAPA I_A - Arhitektonski projekt</b>
Glavni projektant i projektant :	Davor Mateković dipl.ing.arh. A1405
Suradnici :	Tomislav Stojan, dipl.ing.arh. Nataša Mandir, mag.ing.arh.
Geodetske situacije izradio :	Darko Dukovac dipl.ing.geod. br. ovl. 752
Prikaz mjera zaštite od požara sukladan Pravilniku o sadržaju Elaborata zaštite od požara (NN51/2012) izradio :	Goran Kosović dipl.ing.stroj. upisni br. MUP RH 102
Br.t.d./ ZOP:	07/14 07-14-H
Odgovorna osoba :	Tomislav Stojan, dipl.ing.arh., direktor
Datum :	studeni 2020.

TLOCRT

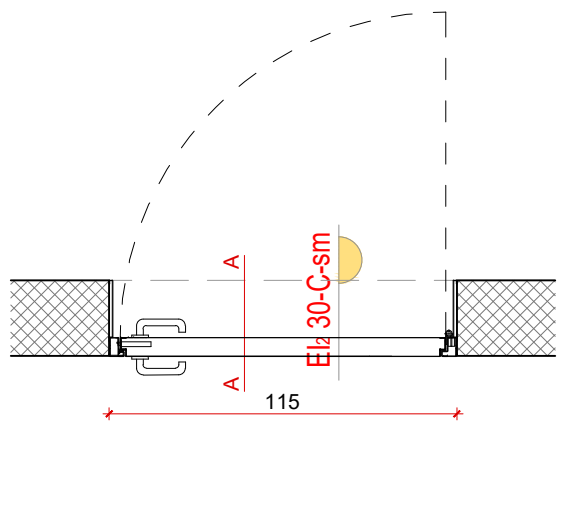
UNUTARNJA  
BRAVARIJA

ST. 01

PROTUPOŽARNA PUNA JEDNOKRILNA ZAOKRETNA  
VRATA VATROOTPORNOSTI 0,5h (klase Elz30-C-Sm)  
OPREMLJENA MECHANIZMOM ZA SAMOZATVARANJE

VRATA SU OPREMLJENA POTREBNIM  
PROTUPOŽARNIM OKOVOM EN 179

115/220 cm kom: D= 3

115/250 cm kom: D= 4  
L=2

100/220 cm kom: D= 1

95/220 cm kom: D= 1

POGLED

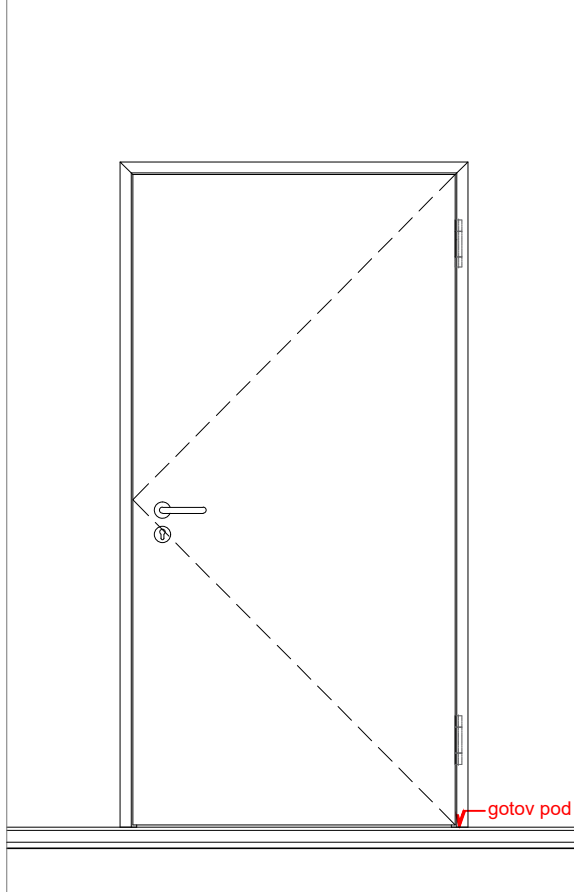

PRESJEK A-A

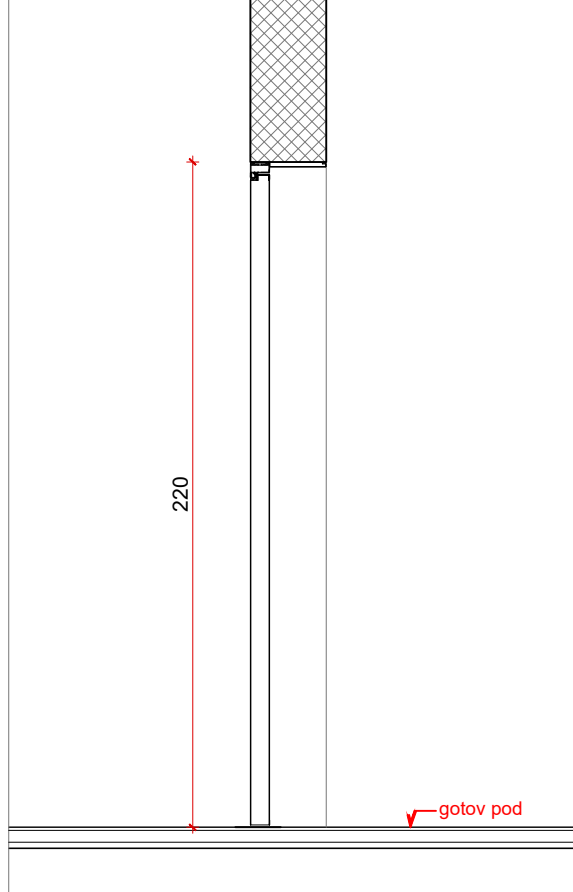

P R O A R H

Proarh mateković d.o.o.  
za arhitektonsko projektiranje

Kneza Mislava 15, Zagreb, 10000, Croatia  
t. +385 1 46 36 015, +385 1 46 36 002, f. + 385 1 45 52 878

investitor: Virovitičko-podravka županija, Trg Ljudevita Patačića 1, 33000 Virovitica OIB: 93362201007	glavni projektant: Davor Mateković, dipl.ing.arh.	sadržaj: <b>SHEME BRAVARIJE</b> m 1:25
	projektant: Davor Mateković, dipl.ing.arh.	
građevina: Centar za kulturu zdravlja - Rekonstrukcija dvorca Janković u Cabuni	suradnici: Tomislav Stojan, dipl.ing.arh., Nataša Mandir, mag.ing.arch.,	br. t.d. 07/14
lokacija: k.č.br. 607/2 k.o. Cabuna		datum: studeni 2020.
faza: <b>IZVEDBENI PROJEKT</b>	direktor: Tomislav Stojan, dipl.ing.arh.	list:

TLOCRT

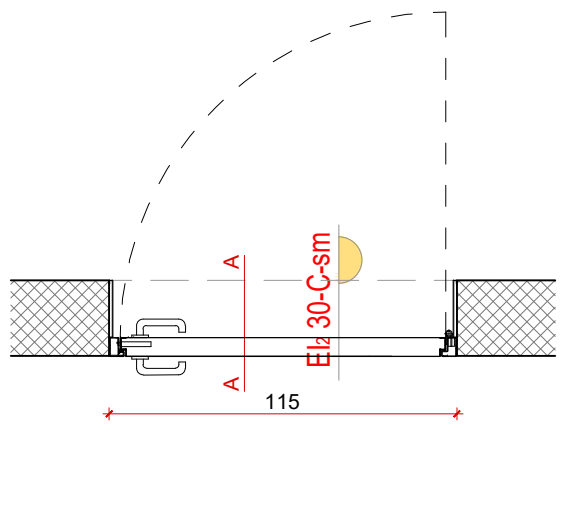
UNUTARNJA  
BRAVARIJA

ST. 02

PROTUPOŽARNA PUNA JEDNOKRILNA ZAOKRETNA  
VRATA VATROOTPORNOSTI 0,5h (klase Elz30-C-Sm)  
OPREMLJENA MECHANIZMOM ZA SAMOZATVARANJE

115/220 cm kom: L= 2

90/220 cm kom: D= 1

90/250 kom: D=1

POGLED

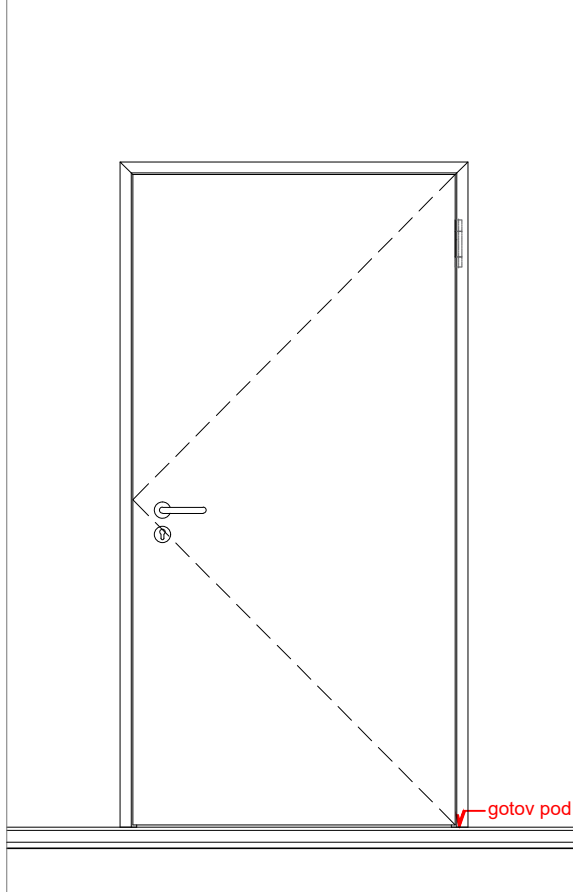

PRESJEK A-A

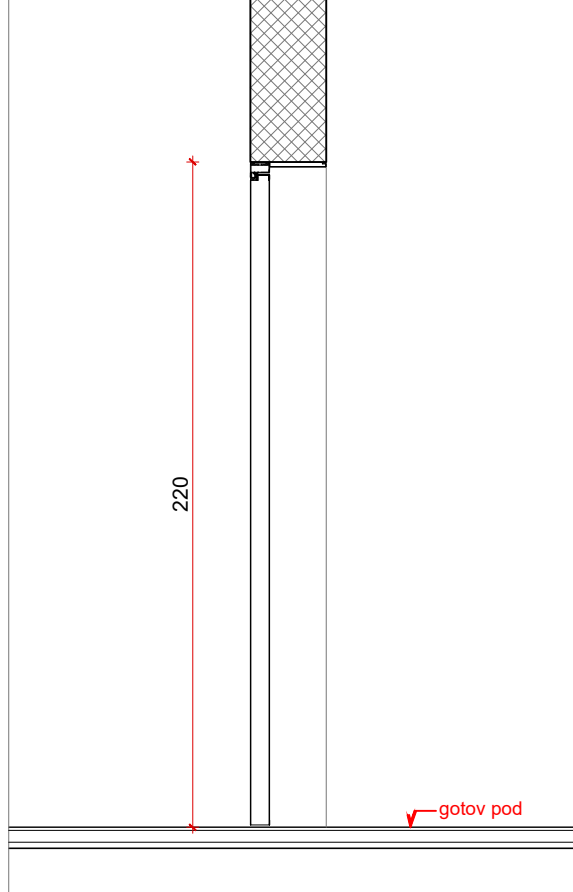

P R O A R H

Proarh mateković d.o.o.  
za arhitektonsko projektiranje

Kneza Mislava 15, Zagreb, 10000, Croatia  
t. +385 1 46 36 015, +385 1 46 36 002, f. + 385 1 45 52 878

investitor: Virovitičko-podravka županija, Trg Ljudevita Patačića 1, 33000 Virovitica OIB: 93362201007	glavni projektant: Davor Mateković, dipl.ing.arh.	sadržaj: <b>SHEME BRAVARIJE</b> m 1:25
	projektant: Davor Mateković, dipl.ing.arh.	
građevina: Centar za kulturu zdravlja - Rekonstrukcija dvorca Janković u Cabuni	suradnici: Tomislav Stojan, dipl.ing.arh., Nataša Mandir, mag.ing.arch.,	br. t.d. 07/14
lokacija: k.č.br. 607/2 k.o. Cabuna		datum: studeni 2020.
faza: <b>IZVEDBENI PROJEKT</b>	direktor: Tomislav Stojan, dipl.ing.arh.	list:

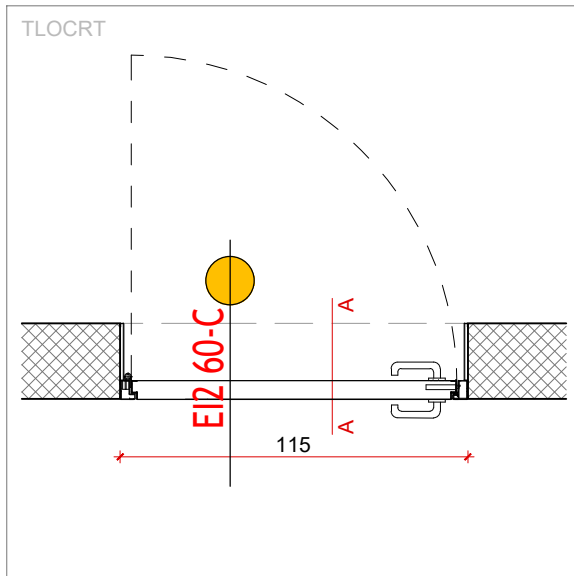

UNUTARNJA  
BRAVARIJA

ST. 03

PROTUPOŽARNA PUNA JEDNOKRILNA ZAOKRETNA  
VRATA VATROOTPORNOSTI 1h (klase E1Z60-C)  
OPREMLJENA MEHANIZMOM ZA SAMOZATVARANJE

115/220 cm

kom: D= 1

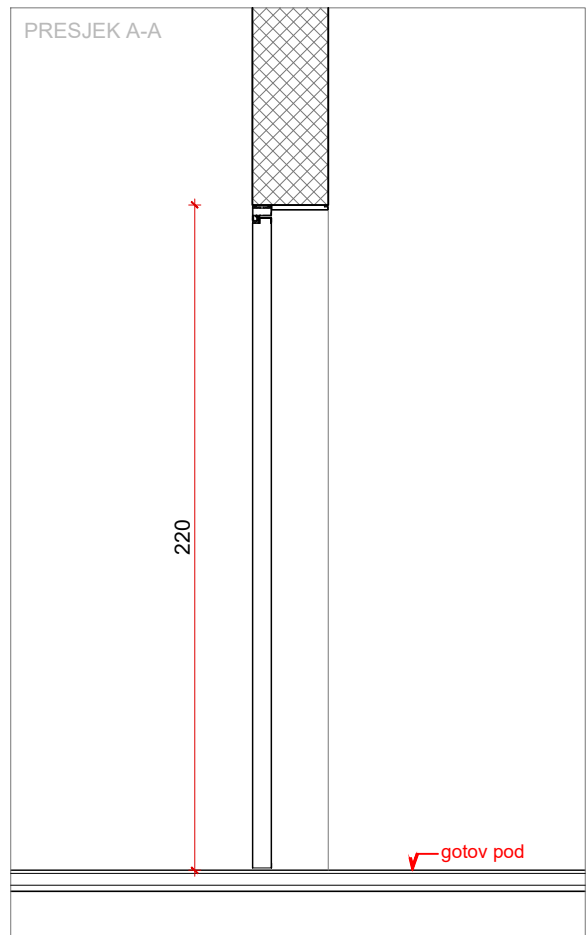
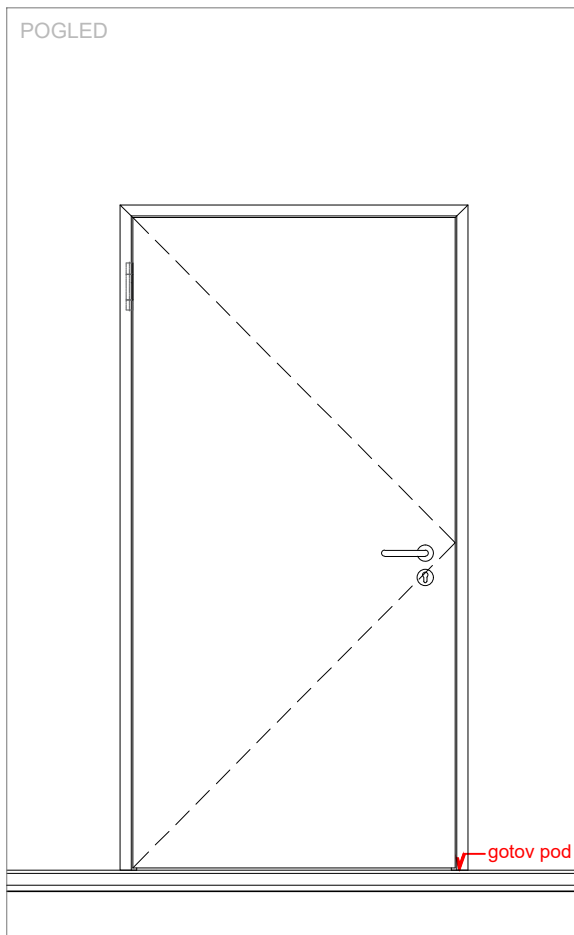

Proarh mateković d.o.o.  
za arhitektonsko projektiranje

Kneza Mislava 15, Zagreb, 10000, Croatia  
t. +385 1 46 36 015, +385 1 46 36 002, f. + 385 1 45 52 878

investitor:	Virovitičko-podravska županija, Trg Ljudevita Patačića 1, 33000 Virovitica OIB: 93362201007	glavni projektant:	Davor Mateković, dipl.ing.arh.	sadržaj:	SHEME BRAVARIJE m 1:25
	građevina:	Centar za kulturu zdravlja - Rekonstrukcija dvorca Janković u Cabuni	projektant:		
lokacija:	k.č.br. 607/2 k.o. Cabuna	suradnici:	Tomislav Stojan, dipl.ing.arh., Nataša Mandir, mag.ing.arch.,	br. t.d.	07/14
faza:	IZVEDBENI PROJEKT	direktor:	Tomislav Stojan, dipl.ing.arh.	datum:	studen 2020.
				list:	

TLOCRT

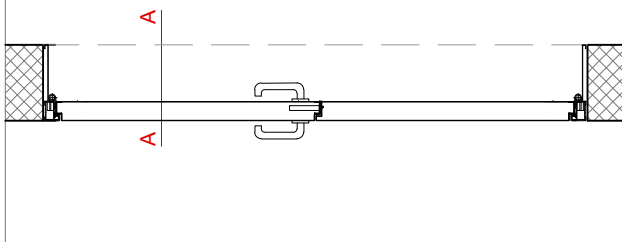
UNUTARNJA  
BRAVARIJA

ST. 04

PROTUPOŽARNA EVAKUACIJSKA PUNA DVOKRILNA  
ZAKRETNA VRATA  
VATROOPORNOSTI 0,5 h (klase EI230-C)  
OPREMLJENA MECHANIZMOM ZA SAMOZATVARANJE  
EVAKUACIJSKI OKOV PREMA NORMI HR EN179

170/220 cm kom: 1

POGLED

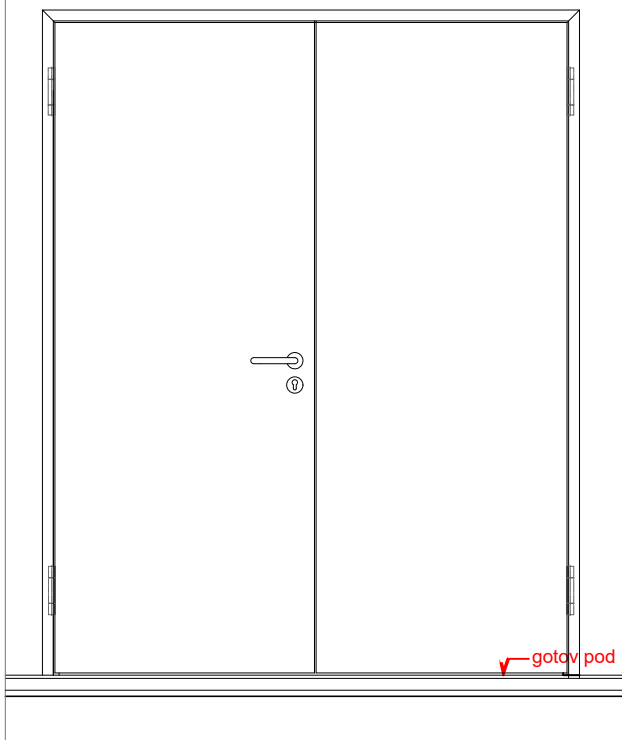

PRESJEK A-A

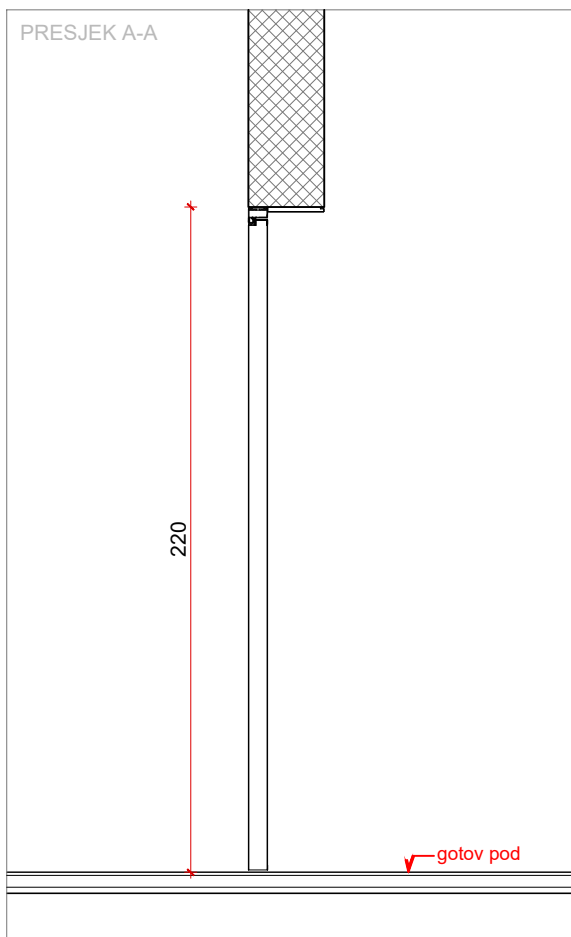

P R O A R H

Proarh mateković d.o.o.  
za arhitektonsko projektiranje

Kneza Mislava 15, Zagreb, 10000, Croatia  
t. +385 1 46 36 015, +385 1 46 36 002, f. + 385 1 45 52 878

investitor: Virovitičko-podravska županija, Trg Ljudevita Patačića 1, 33000 Virovitica OIB: 93362201007	glavni projektant: Davor Mateković, dipl.ing.arh.	sadržaj: <b>SHEME BRAVARIJE</b> m 1:25
	projektant: Davor Mateković, dipl.ing.arh.	
građevina: Centar za kulturu zdravlja - Rekonstrukcija dvorca Janković u Cabuni	suradnici: Tomislav Stojan, dipl.ing.arh., Nataša Mandir, mag.ing.arch.,	br. t.d. 07/14
lokacija: k.č.br. 607/2 k.o. Cabuna		datum: studeni 2020.
faza: <b>IZVEDBENI PROJEKT</b>	direktor: Tomislav Stojan, dipl.ing.arh.	list:

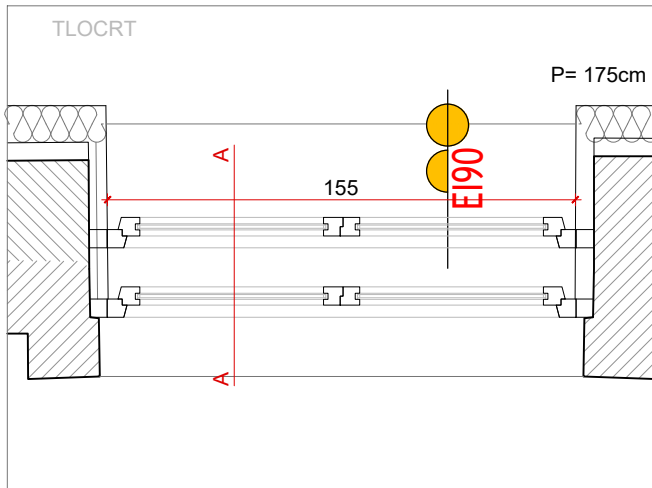

PP VANJSKA  
BRAVARIJA

ST. 05

PROTUPOŽARNI DVOKRILNI PROZOR  
VATROOTPORNOSTI 1,5h (klase EI90)

155/70 cm kom: 1

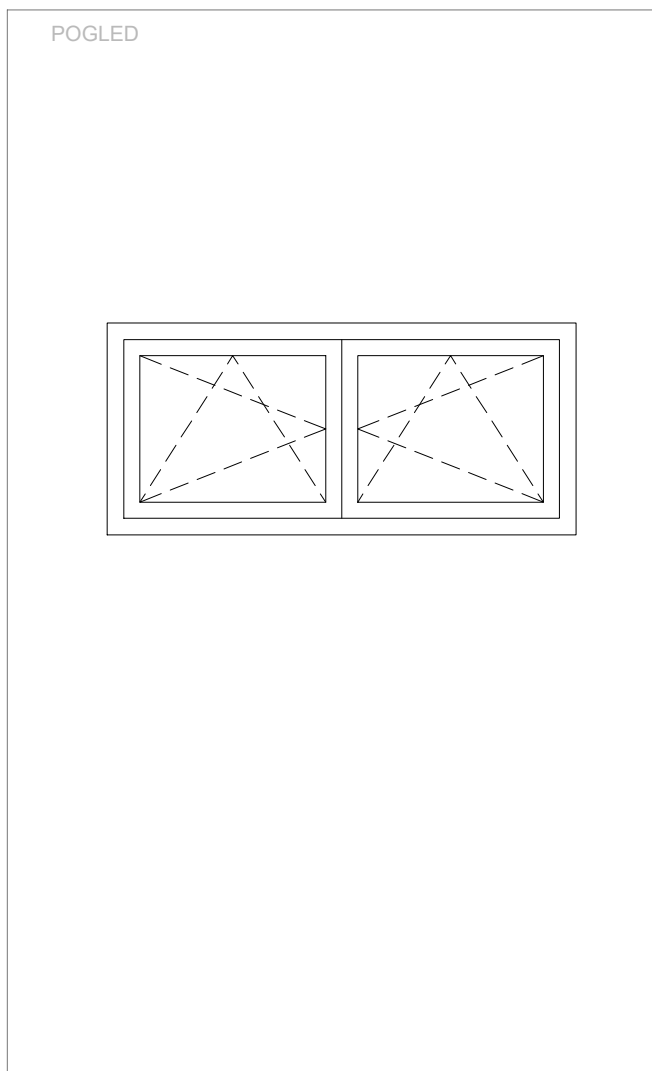

PRESJEK A-A

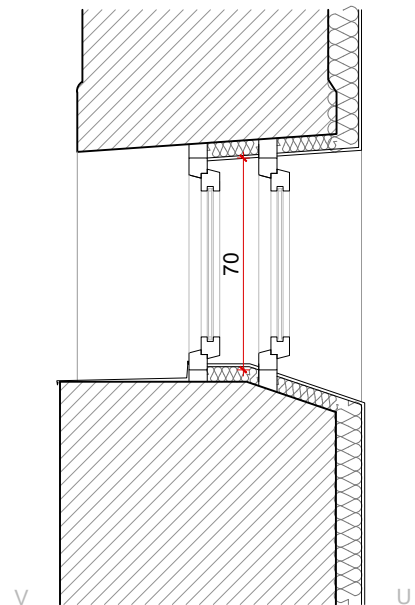

 **P R O A R H**

Proarh tri d.o.o.  
za arhitektonsko projektiranje

t. +385 1 46 36 015, +385 1 46 36 002, f. +385 1 45 52 878  
Kneza Mislava 15, Zagreb, 10000, Croatia

investitor :	OPĆINA SUHOPOLJE, Trg Sv. Terezije 10 Suhopolje, OIB: 56986677718	glavni projektant :	Davor Mateković dia	sadržaj :	<b>HEME STOLARIJE m 1:25</b>
gradevina :	Dvorac Janković - Hospicij Cabuna	projektant :	Davor Mateković dia	br.t.d. :	07/14, 07-14-H
lokacija :	Cabuna, k.č.br. 607 k.o. Cabuna	suradnik :	Bojana Benić dia	datum :	srpanj 2020.
faza :	Glavni projekt	direktor :	Tomislav Stojan dia.	list :	

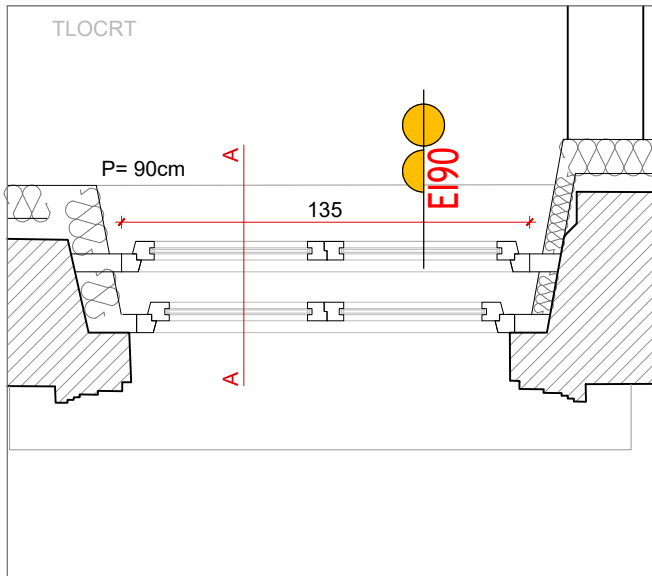

PP VANJSKA  
BRAVARIJA

ST. 06a

DVOKRILNI ZAOKRETNO-OTKLOPNI PROZOR S  
ZAOKRETNO-OTKLOPNIM NADSVJETLOM  
UGRADBA U POSTOJEĆI ZID OD OPEKE  
PROZOR VATROOPOORNOSTI 1,5 h (EI90)

135/210 cm kom: 2

145/210 cm kom: 1

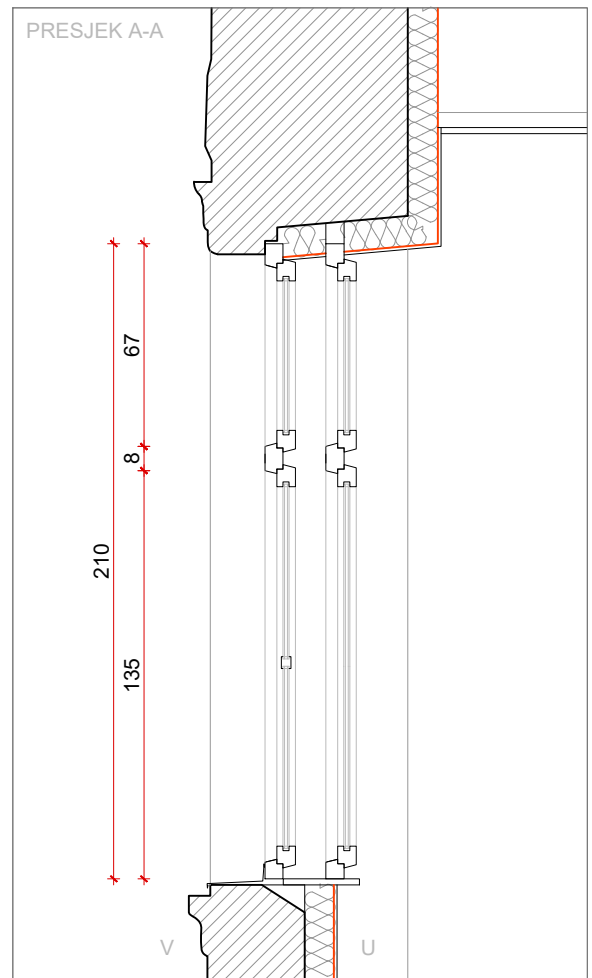
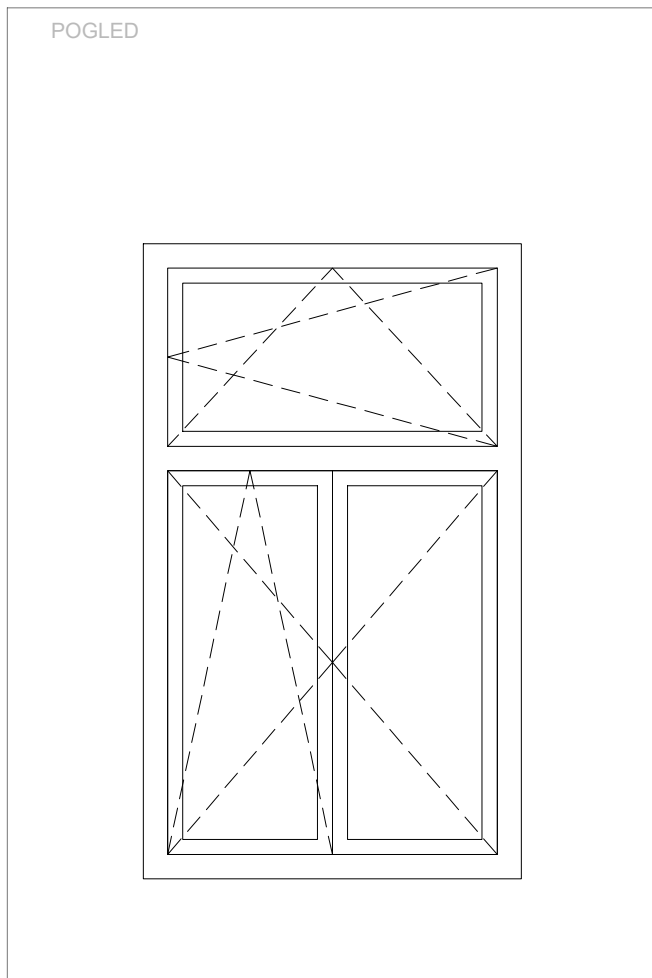

PRO ARH

Proarh mateković d.o.o.  
za arhitektonsko projektiranje

Kneza Mislava 15, Zagreb, 10000, Croatia  
t. +385 1 46 36 015, +385 1 46 36 002, f. + 385 1 45 52 878

investitor: Virovitičko-podravska županija, Trg Ljudevita Patačića 1, 33000 Virovitica OIB: 93362201007	glavni projektant: Davor Mateković, dipl.ing.arh.	sadržaj: <b>SHEME STOLARIJE</b> m 1:25
	projektant: Davor Mateković, dipl.ing.arh.	
građevina: Centar za kulturu zdravlja - Rekonstrukcija dvorca Janković u Cabuni	suradnici: Tomislav Stojan, dipl.ing.arh., Nataša Mandir, mag.ing.arch.,	br. t.d. 07/14
lokacija: k.č.br. 607/2 k.o. Cabuna		datum: studeni 2020.
faza: <b>IZVEDBENI PROJEKT</b>	direktor: Tomislav Stojan, dipl.ing.arh.	list:

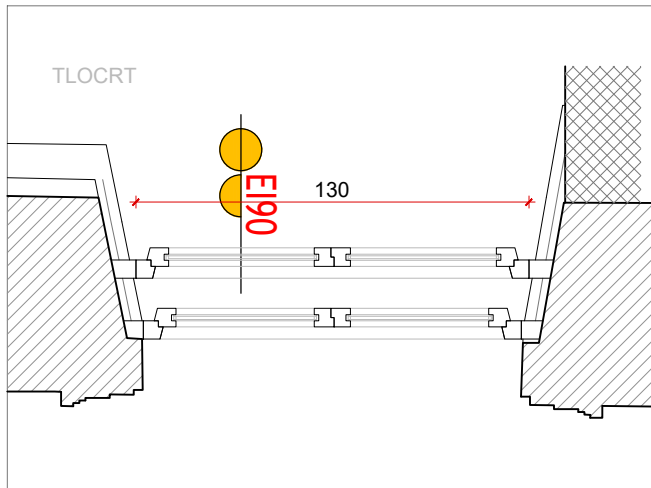

VANJSKA  
STOLARIJA

ST. 6b

DVOKRILNI ZAOKRETNO-OTKLOPNI PROZOR S  
ZAOKRETNO-OTKLOPNIM NADSVJETLOM  
UGRADBA U POSTOJEĆI ZID OD OPEKE

130/230 cm kom: 1

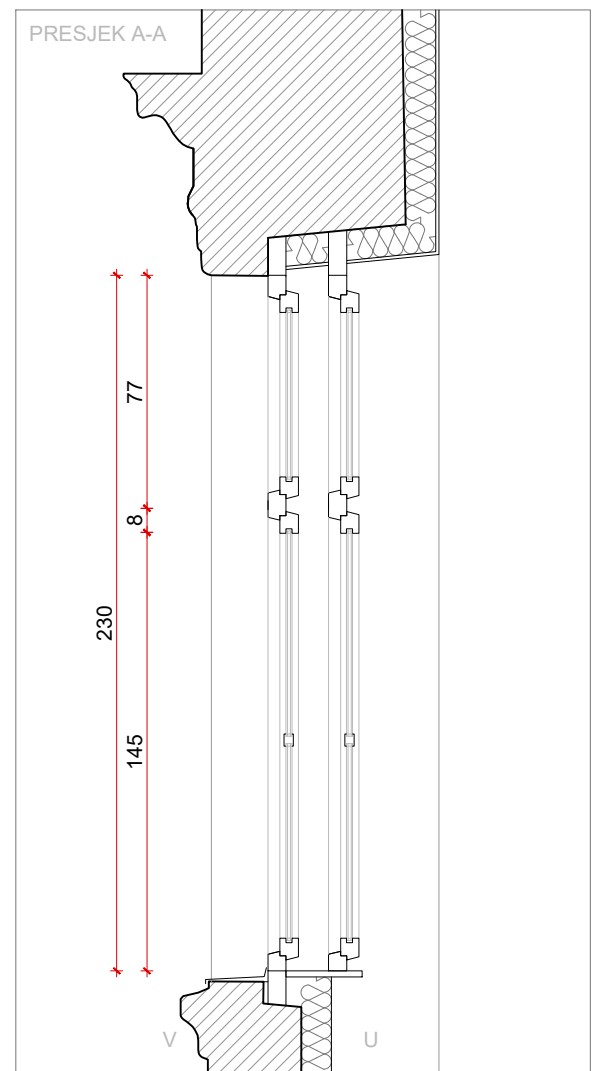
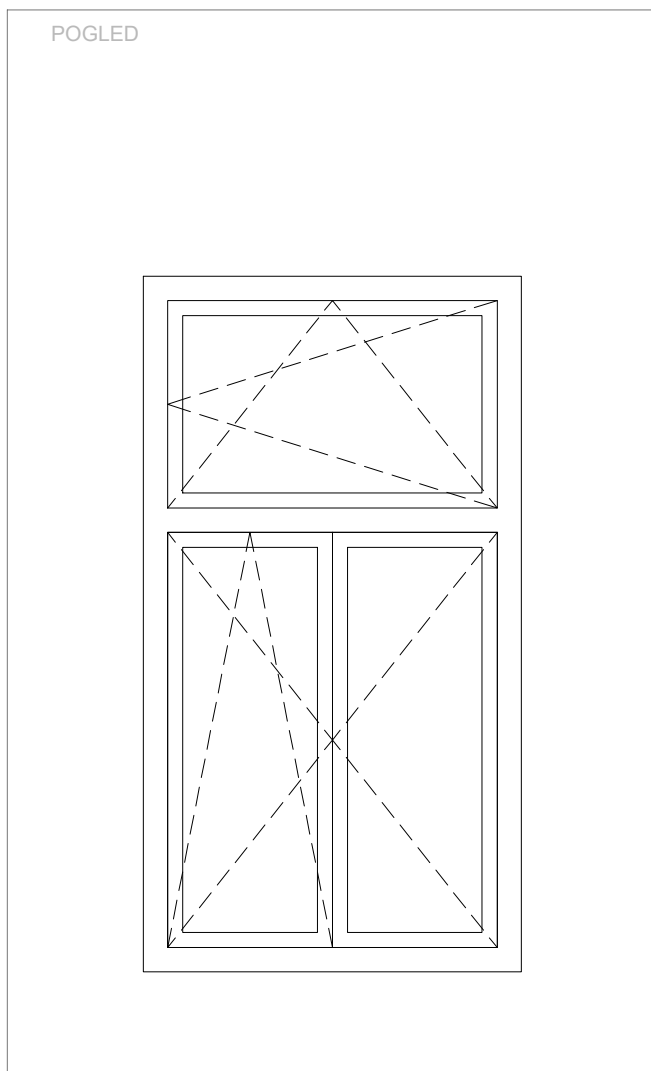

PROARH

Proarh mateković d.o.o.  
za arhitektonsko projektiranje

Kneza Mislava 15, Zagreb, 10000, Croatia  
t. +385 1 46 36 015, +385 1 46 36 002, f. + 385 1 45 52 878

investitor:	Virovitičko-podravska županija, Trg Ljudevita Patačića 1, 33000 Virovitica OIB: 93362201007	glavni projektant:	Davor Mateković, dipl.ing.arh.	sadržaj: SHEME STOLARIJE m 1:25
		projektant:	Davor Mateković, dipl.ing.arh.	
građevina:	Centar za kulturu zdravlja - Rekonstrukcija dvorca Janković u Cabuni	suradnici:	Tomislav Stojan, dipl.ing.arh., Nataša Mandir, mag.ing.arch.,	br. t.d. 07/14
lokacija:	k.č.br. 607/2 k.o. Cabuna			datum: studeni 2020.
faza:	IZVEDBENI PROJEKT	direktor:	Tomislav Stojan, dipl.ing.arh.	list:



TLOCRT

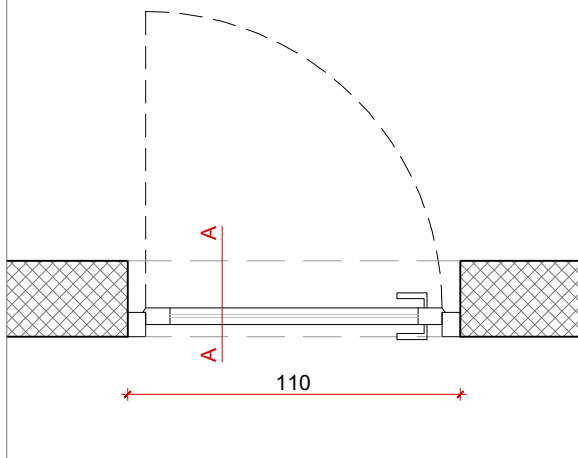

UNUTARNJA  
BRAVARIJA

ST. 07

EVAKUACIJSKA OSTAKLJENA JEDNOKRILNA  
ZAKRETNA VRATA OPREMLJENA UREĐAJEM ZA  
FIKSIRANJE U STALNO OTVORENOM POLOŽAJU  
PREMA NORMI HR EN1125

110/220 cm kom: **D= 1**

POGLED

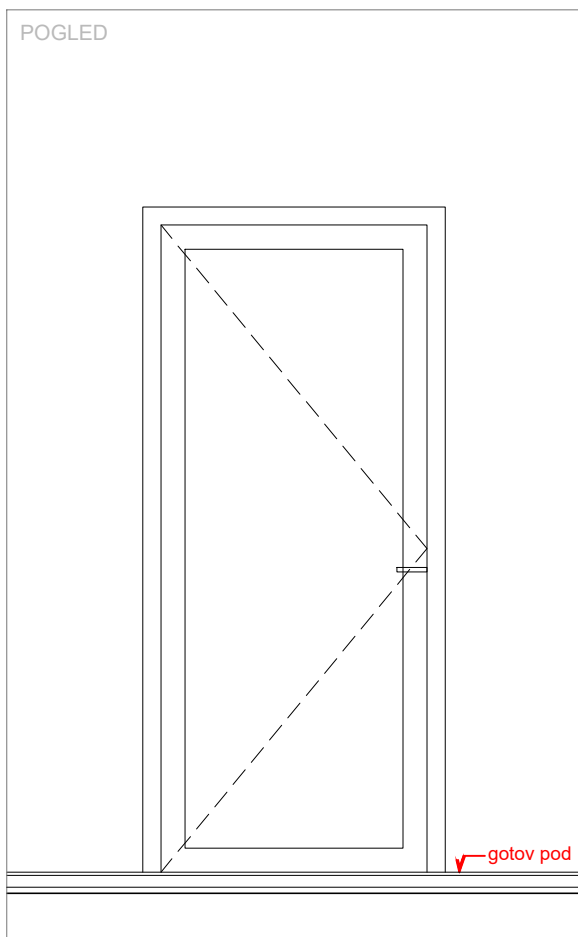

PRESJEK A-A

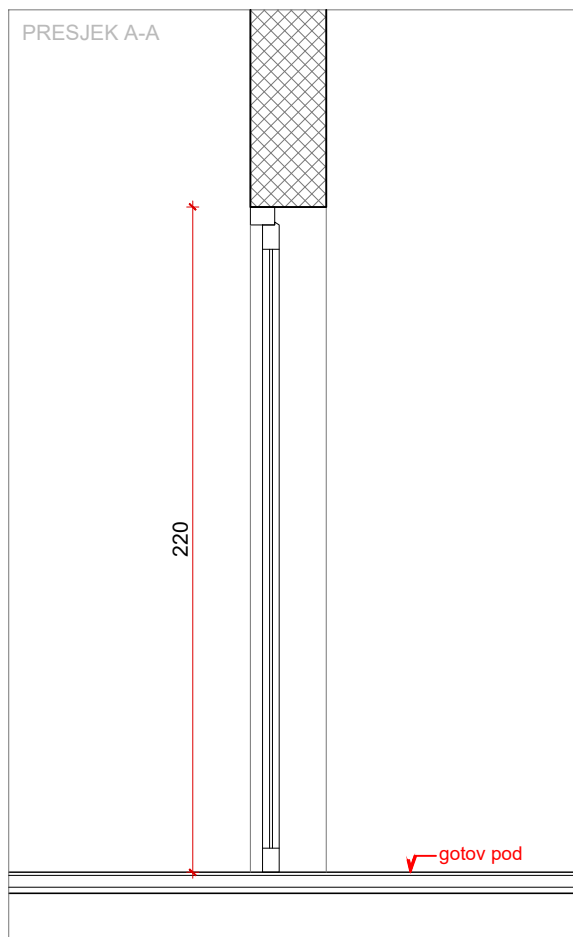

PROARH

Proarh mateković d.o.o.  
za arhitektonsko projektiranje

Kneza Mislava 15, Zagreb, 10000, Croatia  
t. +385 1 46 36 015, +385 1 46 36 002, f. + 385 1 45 52 878

investitor: Virovitičko-podravska županija, Trg Ljudevita Patačića 1, 33000 Virovitica OIB: 93362201007	glavni projektant: Davor Mateković, dipl.ing.arh.	sadržaj: <b>SHEME BRAVARIJE</b> m 1:25
	projektant: Davor Mateković, dipl.ing.arh.	
građevina: Centar za kulturu zdravlja - Rekonstrukcija dvorca Janković u Cabuni	suradnici: Tomislav Stojan, dipl.ing.arh., Nataša Mandir, mag.ing.arch.,	br. t.d. 07/14
lokacija: k.č.br. 607/2 k.o. Cabuna		datum: studeni 2020.
faza: <b>IZVEDBENI PROJEKT</b>	direktor: Tomislav Stojan, dipl.ing.arh.	list:

TLOCRT

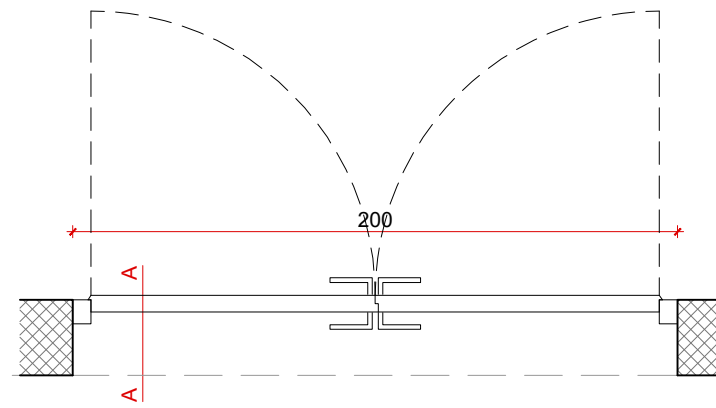

UNUTARNJA  
BRAVARIJA

ST. 08

EVAKUACIJSKA PUNA DVOKRILNA ZAOKRETNNA  
VRATA.

180/250 cm kom: 1

POGLED

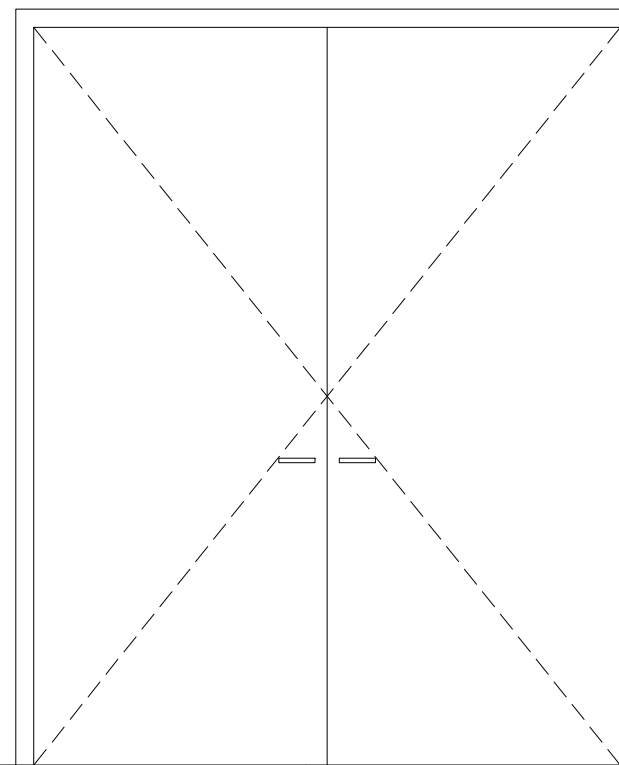

PRESJEK A-A

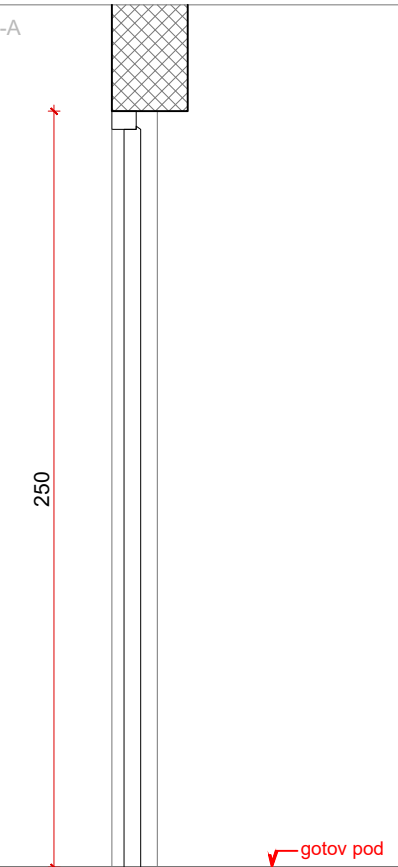

**PROARH** Proarh mateković d.o.o.  
za arhitektonsko projektiranje

Kneza Mislava 15, Zagreb, 10000, Croatia  
t. +385 1 46 36 015, +385 1 46 36 002, f. + 385 1 45 52 878

investitor: Virovitičko-podravska županija, Trg Ljudevita Patačića 1, 33000 Virovitica OIB: 93362201007	glavni projektant: Davor Mateković, dipl.ing.arh. projektant: Davor Mateković, dipl.ing.arh.	sadržaj: <b>HEME BRAVARIJE</b> m 1:25
gradevina: Centar za kulturu zdravlja - Rekonstrukcija dvorca Janković u Cabuni	suradnici: Tomislav Stojan, dipl.ing.arh., Nataša Mandir, mag.ing.arch.	br. t.d. 07/14
lokacija: k.č.br. 607/2 k.o. Cabuna	direktor: Tomislav Stojan, dipl.ing.arh.	datum: studeni 2020.
faza: <b>IZVEDBENI PROJEKT</b>		list:

TLOCRT

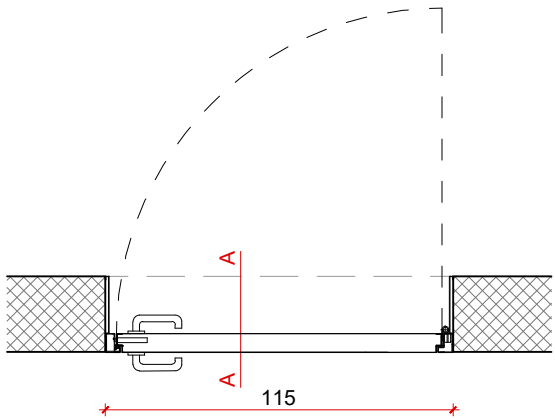
UNUTARNJA  
BRAVARIJA

ST. 09

PROTUPOŽARNA PUNA JEDNOKRILNA ZAOKRETNA  
VRATA VATROOTPORNOSTI 0,5h (klase EI230-C-Sm)  
OPREMLJENA MECHANIZMOM ZA SAMOZATVARANJE

VRATA SU OPREMLJENA POTREBNIM  
PROTUPOŽARNIM OKOVOM EN 179

120/220 cm kom: L= 1

115/250 cm kom: D=3  
L = 190/250 cm kom: L=1  
D=2

100/250 cm kom: L=1

POGLED

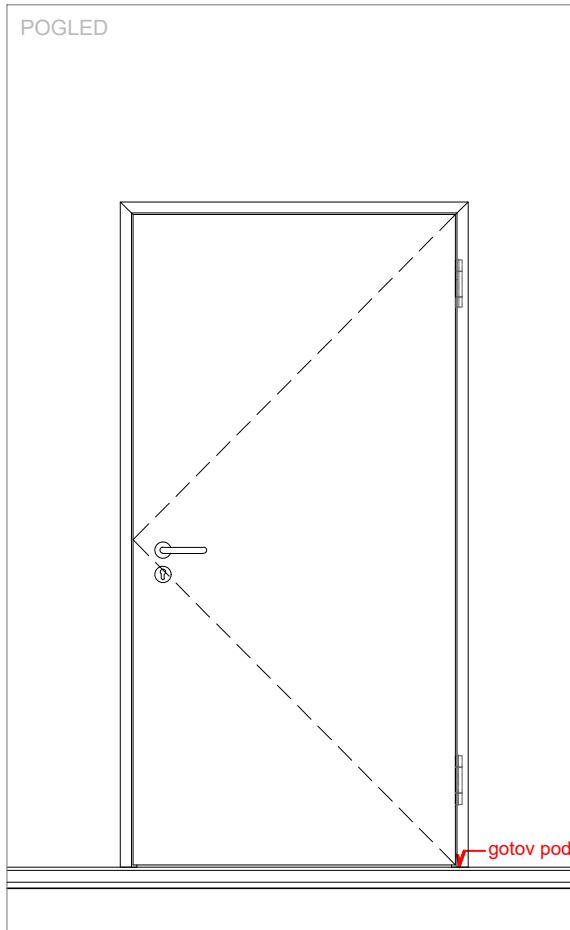

PRESJEK A-A

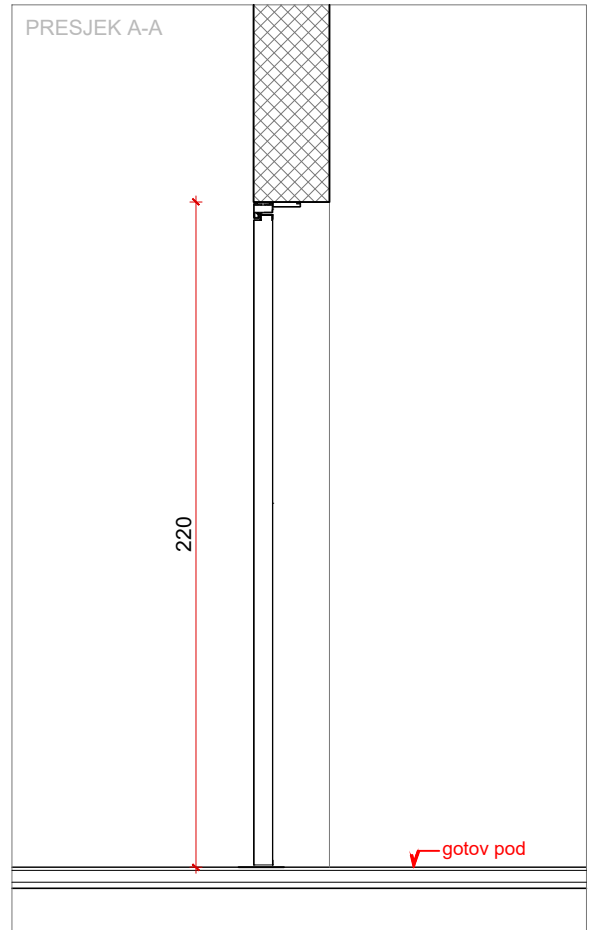

P R O A R H

Proarh mateković d.o.o.  
za arhitektonsko projektiranje

Kneza Mislava 15, Zagreb, 10000, Croatia  
t. +385 1 46 36 015, +385 1 46 36 002, f. + 385 1 45 52 878

investitor: Virovitičko-podravka županija, Trg Ljudevita Patačića 1, 33000 Virovitica OIB: 93362201007	glavni projektant: Davor Mateković, dipl.ing.arh.	sadržaj: <b>SHEME BRAVARIJE</b> m 1:25
	projektant: Davor Mateković, dipl.ing.arh.	
građevina: Centar za kulturu zdravlja - Rekonstrukcija dvorca Janković u Cabuni	suradnici: Tomislav Stojan, dipl.ing.arh., Nataša Mandir, mag.ing.arch.,	br. t.d. 07/14
lokacija: k.č.br. 607/2 k.o. Cabuna		datum: studeni 2020.
faza: <b>IZVEDBENI PROJEKT</b>	direktor: Tomislav Stojan, dipl.ing.arh.	list:

KROV

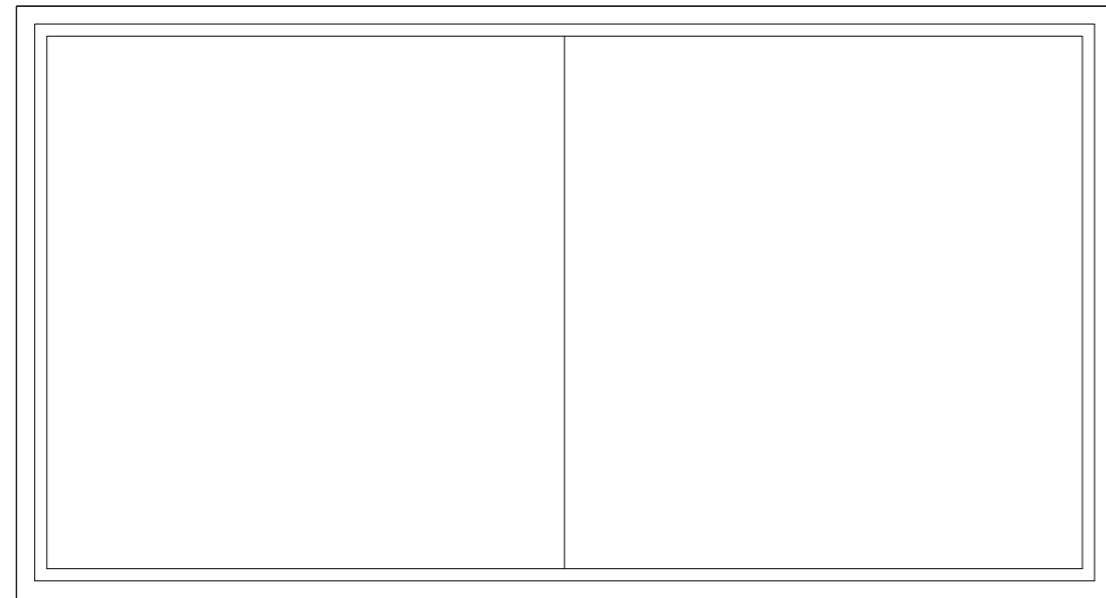

POGLED A-A

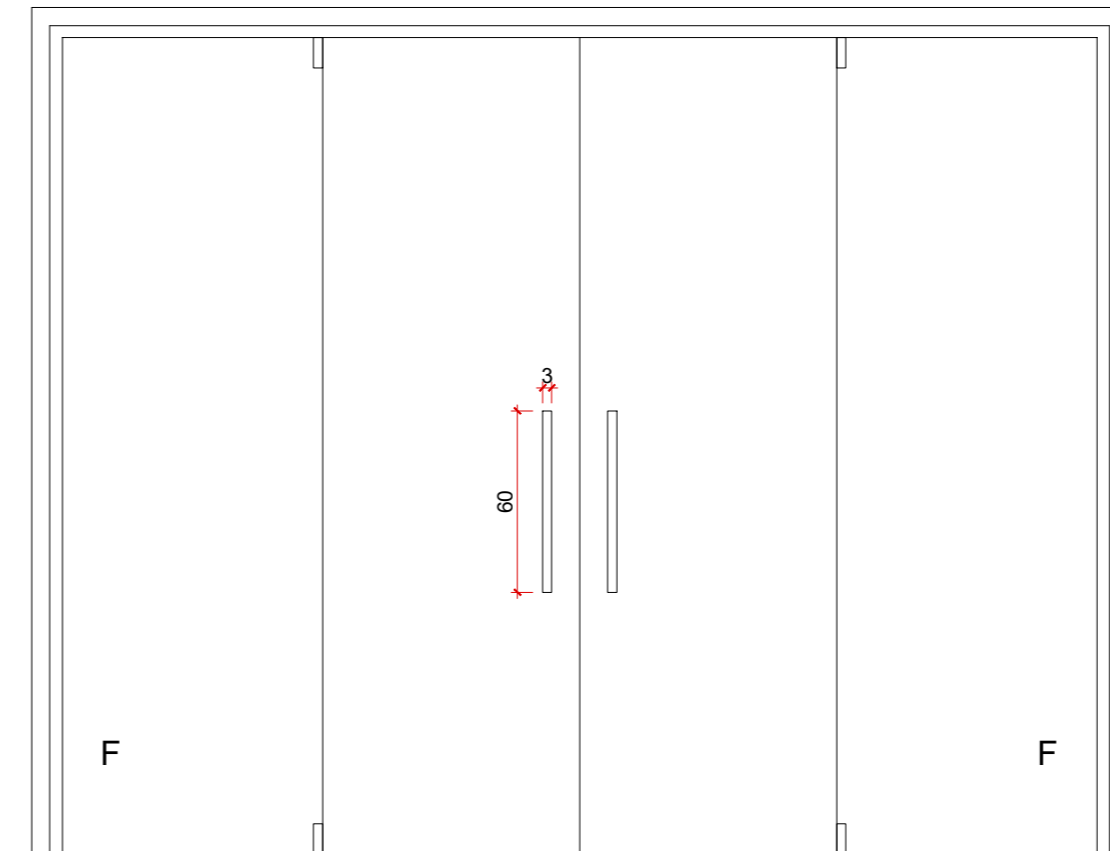

UNUTARNJA  
BRAVARIJA

ST. 10

EVAKUACIJSKA OSTAKLJENA FIKSNA STIJENA  
SASTAVLJENA OD JEDNIH DVOKRILNIH ZAOKRETNIH  
VRATA I SEDAM FIKSNIH KOMADA

734/280 cm kom: 1

POGLED B-B

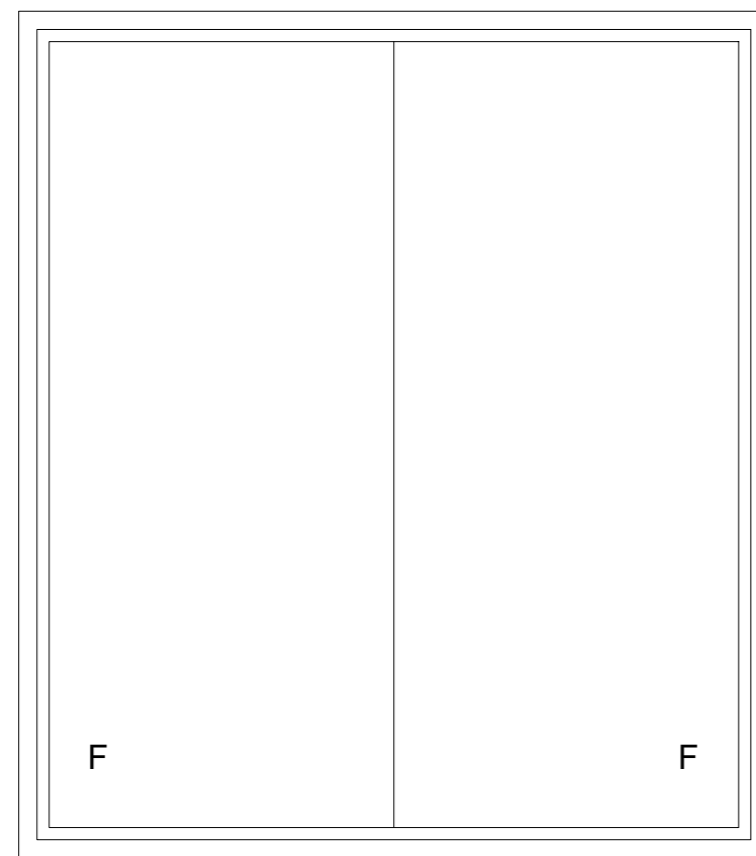

TLOCRT

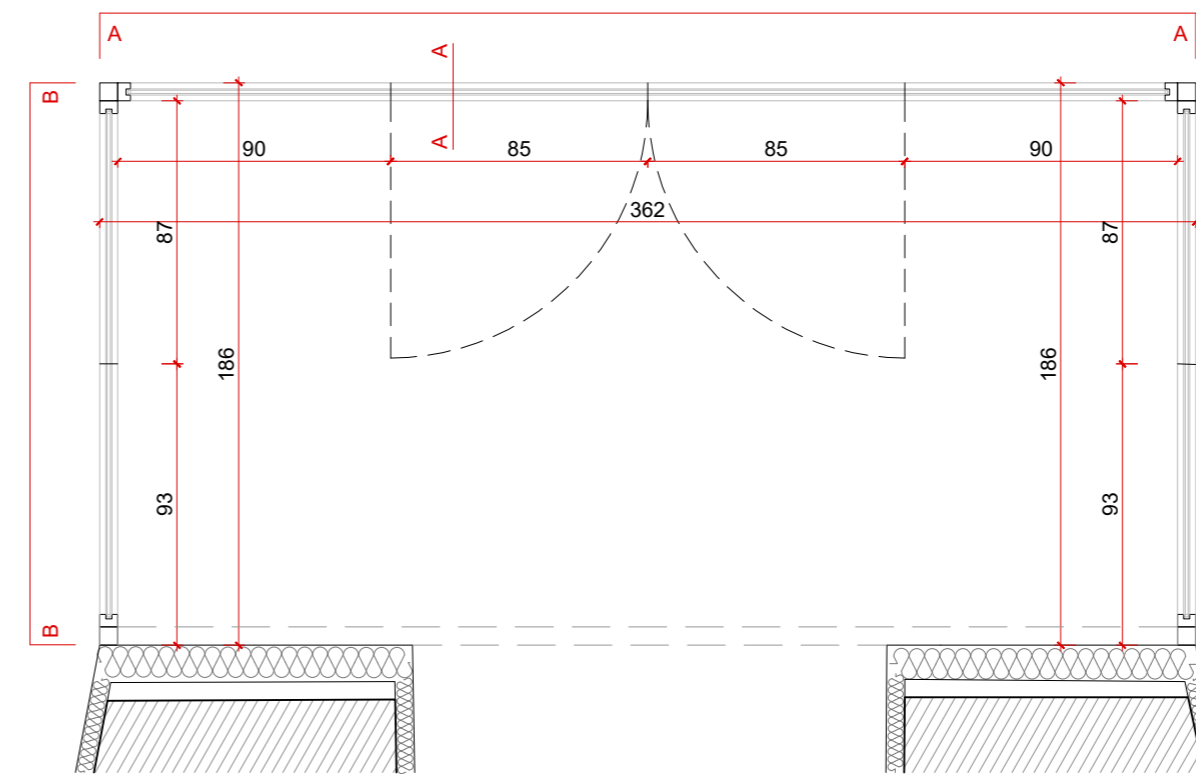

PRESJEK A-A

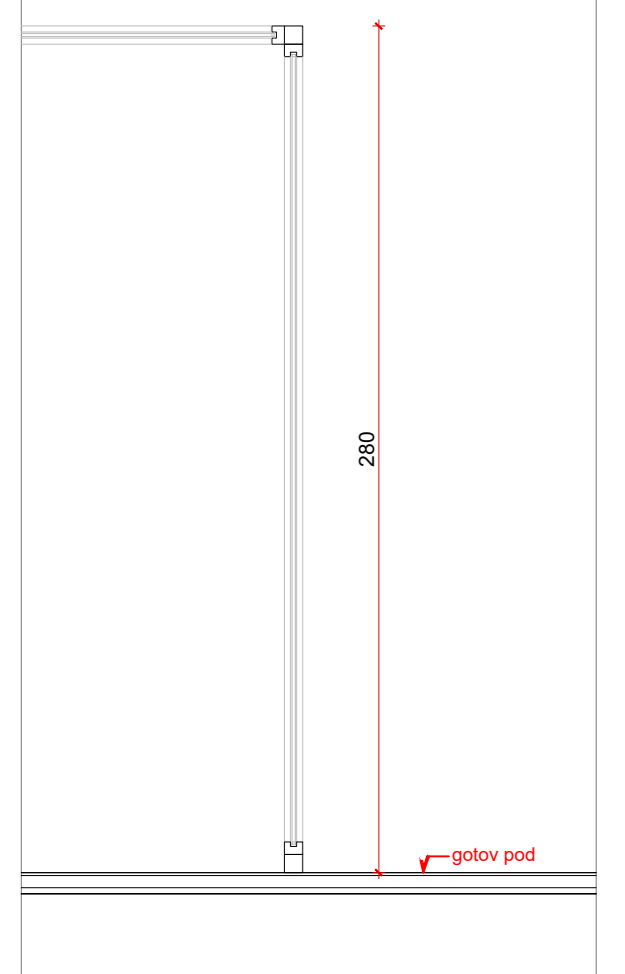

**PROARH** Proarh mateković d.o.o. Kneza Mislava 15, Zagreb, 10000, Croatia  
za arhitektonsko projektiranje t. +385 1 46 36 015, +385 1 46 36 002, f. + 385 1 45 52 878

investitor:	Virovitičko-podravska županija, Trg Ljudevita Patačića 1, 33000 Virovitica OIB: 93362201007	glavni projektant:	Davor Mateković, dipl.ing.arh.	sadržaj:	<b>SHEME BRAVARIJE</b> m 1:25
građevina:	Centar za kulturu zdravlja - Rekonstrukcija dvorca Janković u Cabuni	projektant:	Davor Mateković, dipl.ing.arh.	br. t.d.	07/14
lokacija:	k.č.br. 607/2 k.o. Cabuna	suradnici:	Tomislav Stojan, dipl.ing.arh., Nataša Mandir, mag.ing.arch.	datum:	studenj 2020.
faza:	IZVEDBENI PROJEKT	direktor:	Tomislav Stojan, dipl.ing.arh.	list:	

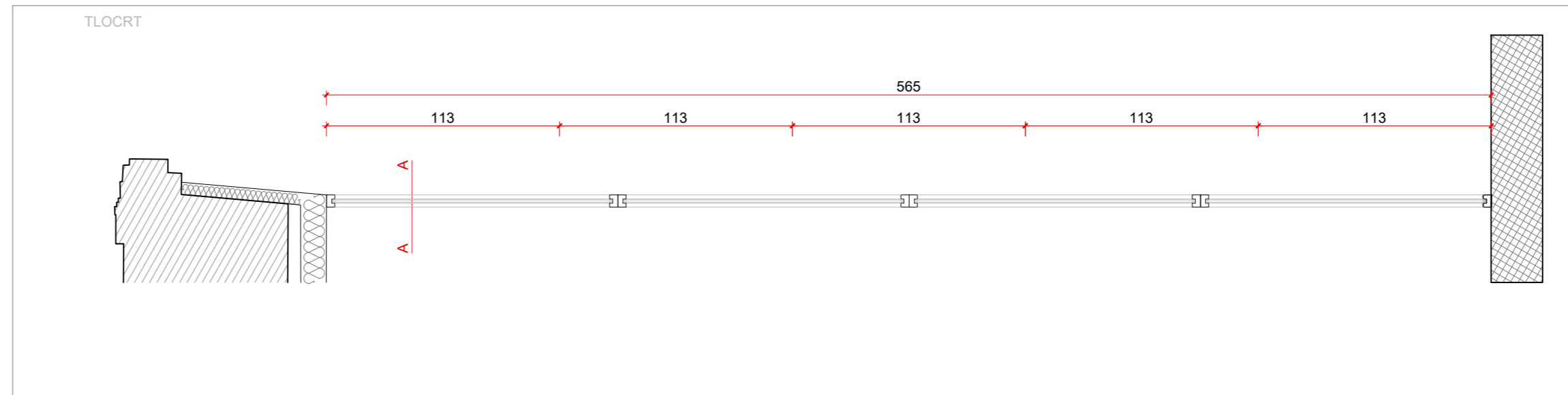

UNUTARNJA  
BRAVARIJA **ST. 11**

OSTAKLJENA FIKSNA STIJENA SASTAVLJENA OD  
ŠEST FIKSNIH KOMADA  
565/400 cm kom: 1

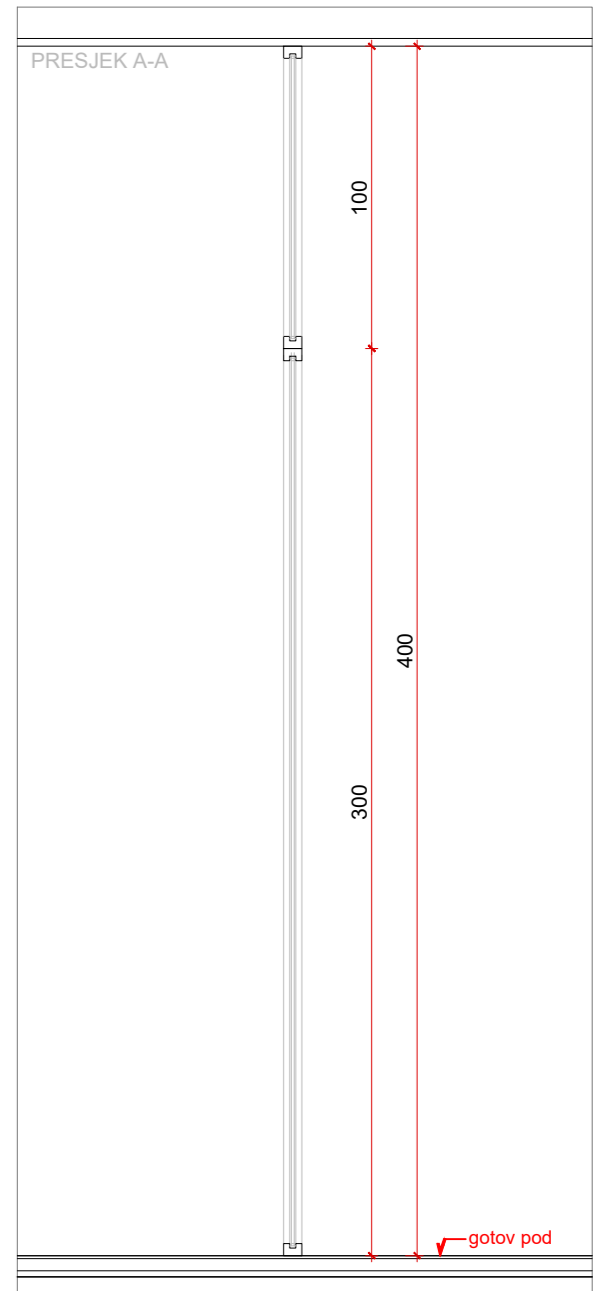
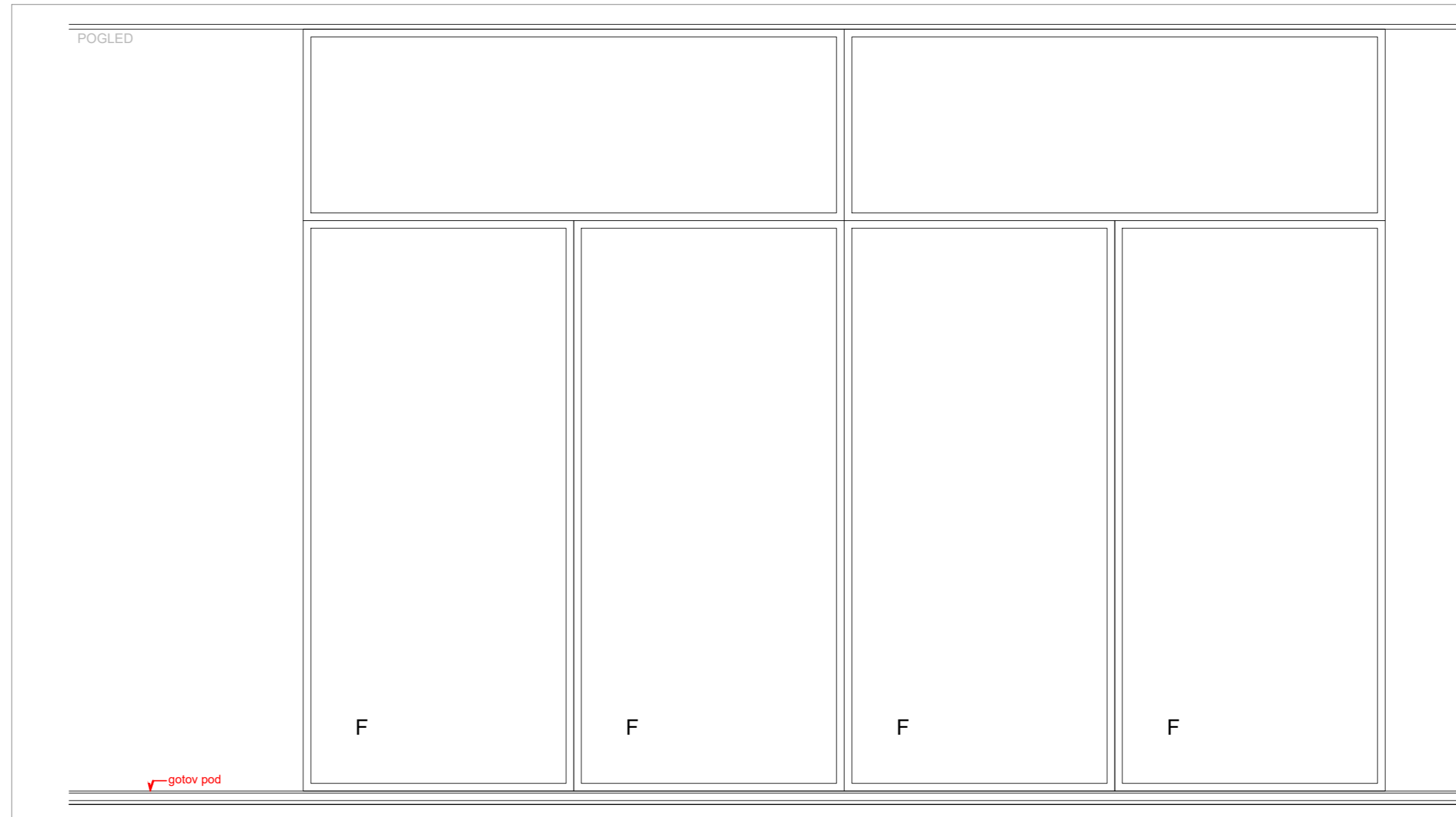

investitor:	Virovitičko-podravaska županija, Trg Ljudevita Patačića 1, 33000 Virovitica OIB: 93362201007	glavni projektant:	Davor Mateković, dipl.ing.arh.	sadržaj:	HEME BRAVARIJE m 1:25
građevina:	Centar za kulturu zdravlja - Rekonstrukcija dvorca Janković u Cabuni	projektant:	Davor Mateković, dipl.ing.arh.	br. t.d.	07/14
lokacija:	k.č.br. 607/2 k.o. Cabuna	suradnici:	Tomislav Stojan, dipl.ing.arh., Nataša Mandir, mag.ing.arch.,	datum:	studen 2020.
faza:	IZVEDBENI PROJEKT	direktor:	Tomislav Stojan, dipl.ing.arh.	list:	

TLOCRT

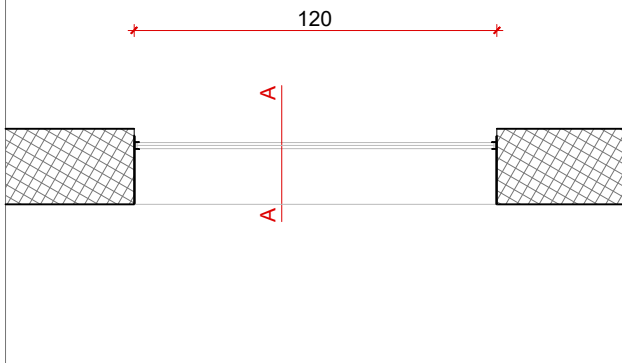

UNUTARNJA  
BRAVARIJA

ST. 12

FIKSNA OSTAKLJENA STIJENA

120/355 cm kom: 5

POGLED

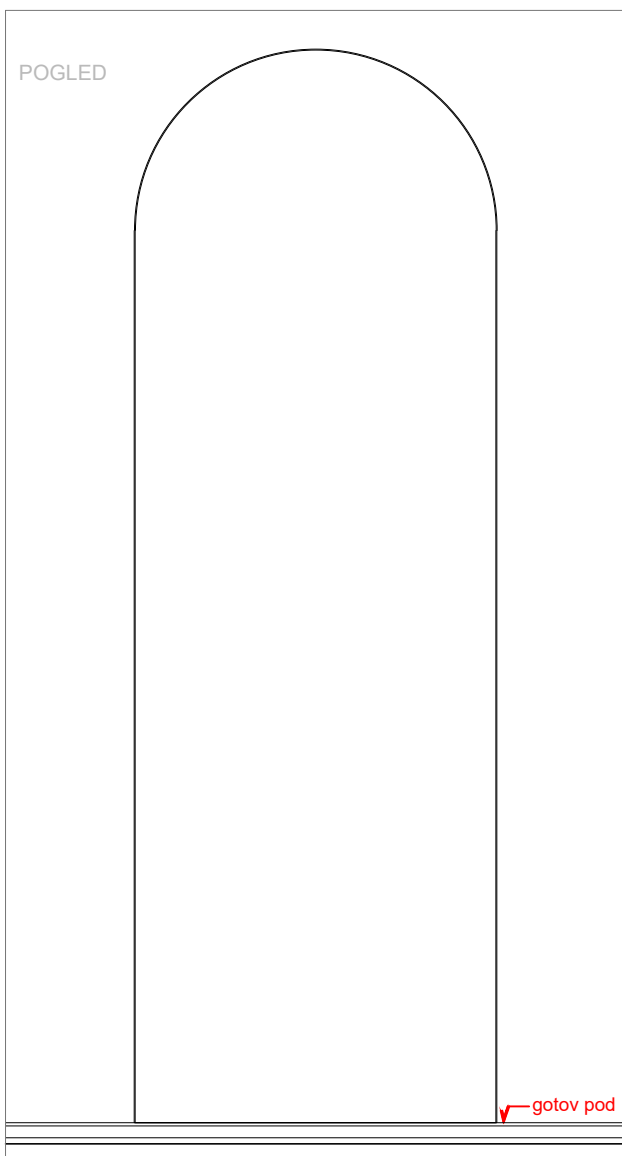

PRESJEK A-A

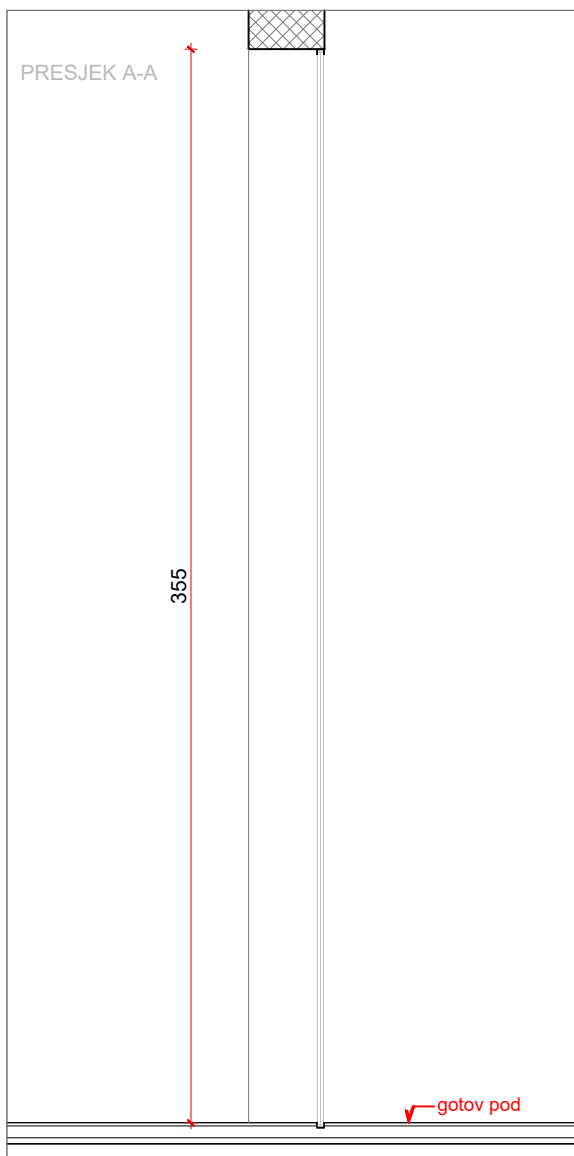

**P R O A R H**

Proarh mateković d.o.o.  
za arhitektonsko projektiranje

Kneza Mislava 15, Zagreb, 10000, Croatia  
t. +385 1 46 36 015, +385 1 46 36 002, f. + 385 1 45 52 878

investitor: Virovitičko-podravska županija, Trg Ljudevita Patačića 1, 33000 Virovitica OIB: 93362201007	glavni projektant: Davor Mateković, dipl.ing.arh.	sadržaj:
	projektant: Davor Mateković, dipl.ing.arh.	
građevina: Centar za kulturu zdravlja - Rekonstrukcija dvorca Janković u Cabuni	suradnici: Tomislav Stojan, dipl.ing.arh., Nataša Mandir, mag.ing.arch.,	br. t.d. 07/14
lokacija: k.č.br. 607/2 k.o. Cabuna		datum: studeni 2020.
faza: IZVEDBENI PROJEKT	direktor: Tomislav Stojan, dipl.ing.arh.	list:

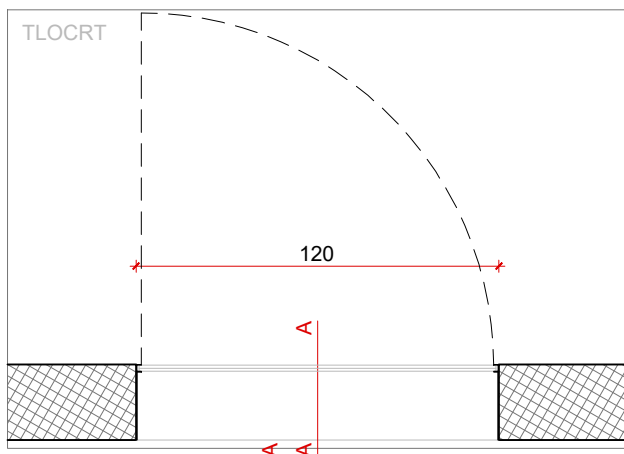

UNUTARNJA  
BRAVARIJA

ST. 13

DVODJELNA OSTAKLJENA STIJENA SASTAVLJENA  
OD JEDNIH JEDNOKRILNIH ZAOKRETNIH VRATA I  
JEDNOG FIKSNOG KOMADA

120/355 cm L=2  
D=1

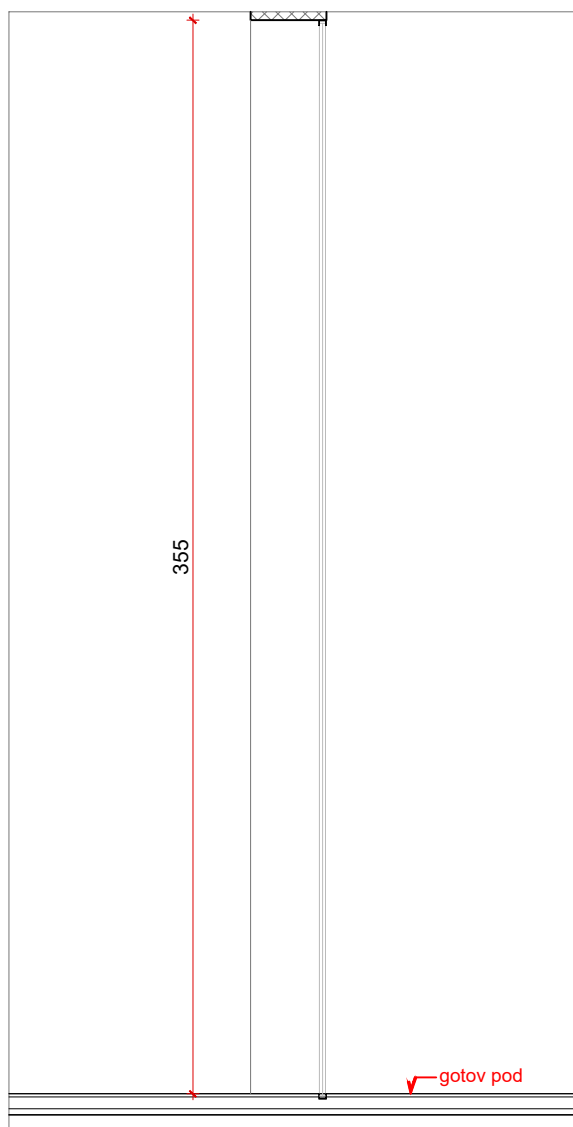
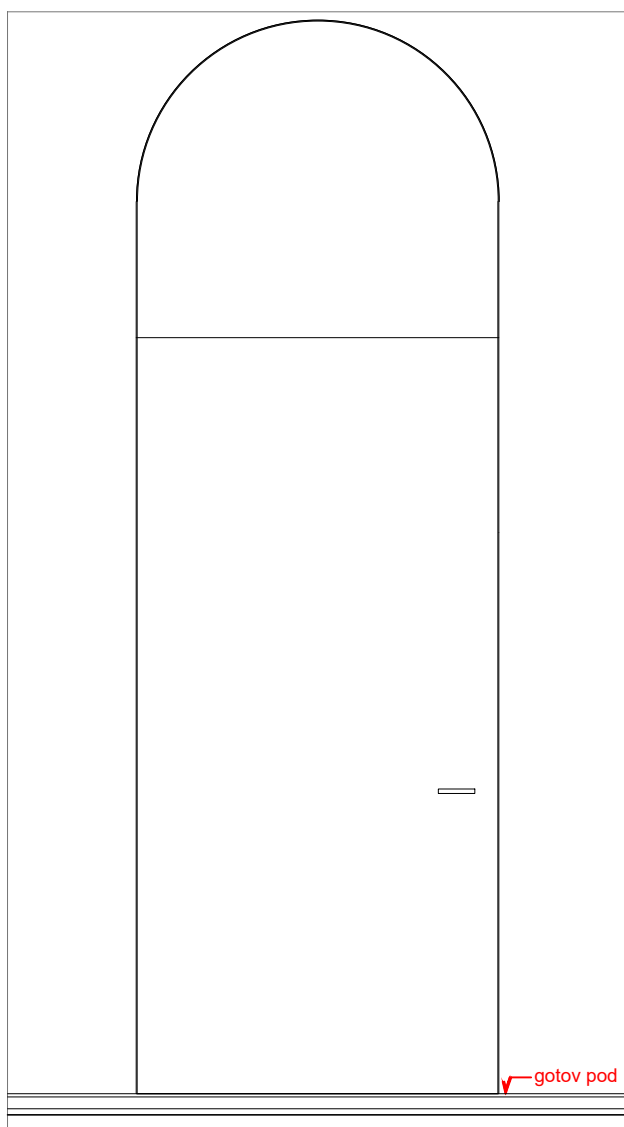

PROARH

Proarh mateković d.o.o.  
za arhitektonsko projektiranje

Kneza Mislava 15, Zagreb, 10000, Croatia  
t. +385 1 46 36 015, +385 1 46 36 002, f. + 385 1 45 52 878

investitor:	Virovitičko-podravaska županija, Trg Ljudevita Patačića 1, 33000 Virovitica OIB: 93362201007	glavni projektant:	Davor Mateković, dipl.ing.arh.	sadržaj:	
građevina:	Centar za kulturu zdravlja - Rekonstrukcija dvorca Janković u Cabuni	projektant:	Davor Mateković, dipl.ing.arh.	br. t.d.	07/14
lokacija:	k.č.br. 607/2 k.o. Cabuna	suradnici:	Tomislav Stojan, dipl.ing.arh., Nataša Mandir, mag.ing.arch.,	datum:	studen 2020.
faza:	IZVEDBENI PROJEKT	direktor:	Tomislav Stojan, dipl.ing.arh.	list:	

TLOCRT

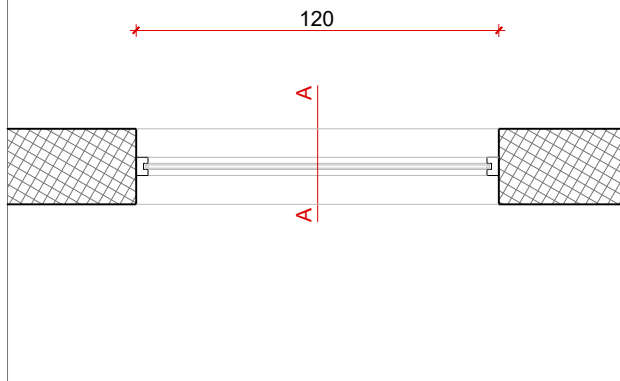

UNUTARNJA  
BRAVARIJA

ST. 14

FIKSNA STIJENA

120/300 cm kom: 3

POGLED

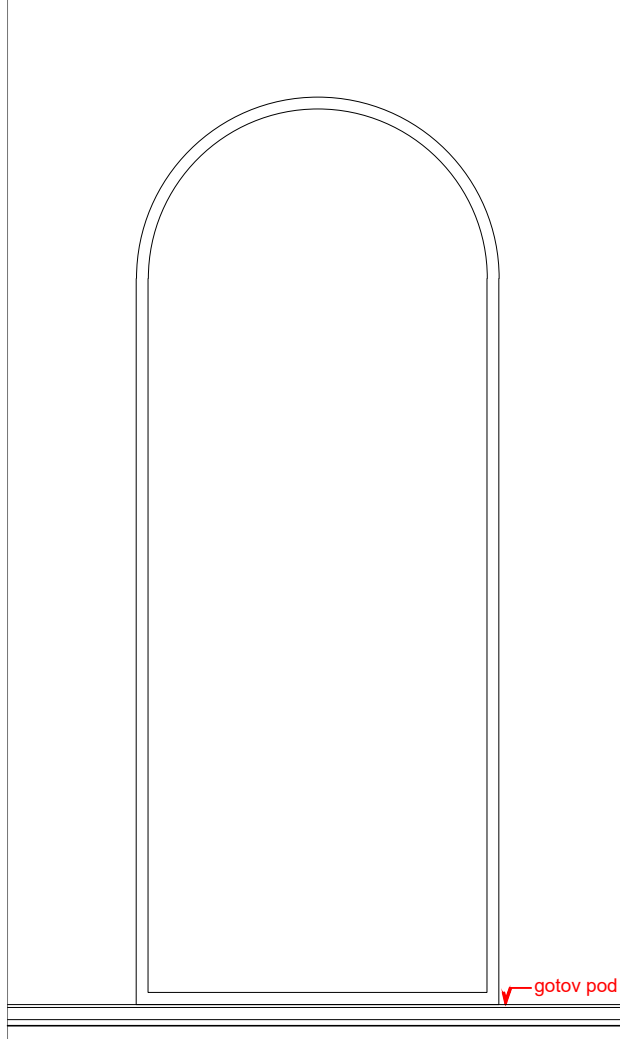

PRESJEK A-A

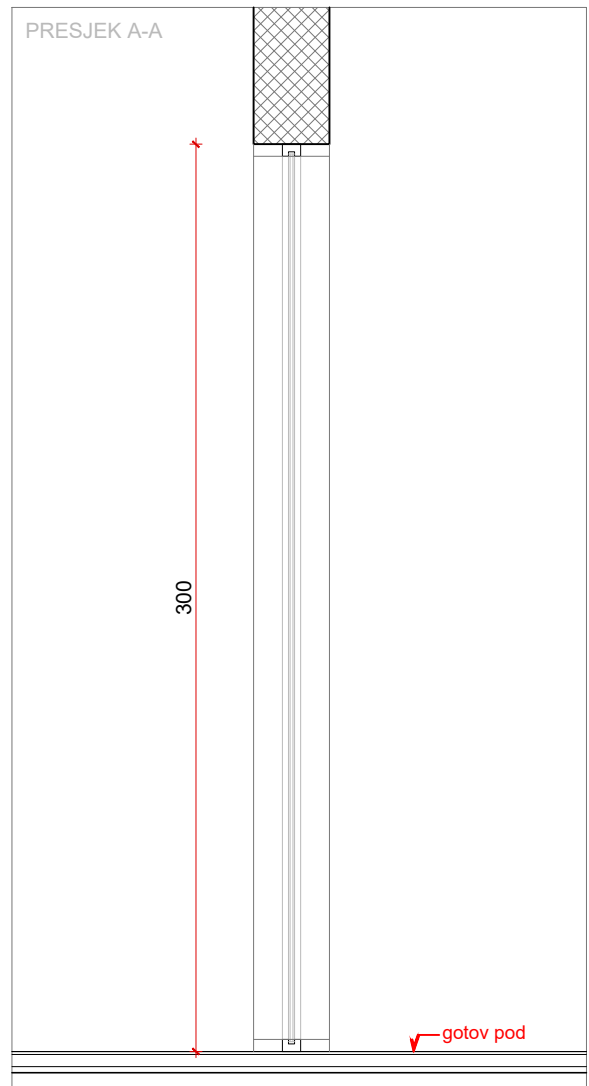

**P R O A R H**

Proarh mateković d.o.o.  
za arhitektonsko projektiranje

Kneza Mislava 15, Zagreb, 10000, Croatia  
t. +385 1 46 36 015, +385 1 46 36 002, f. + 385 1 45 52 878

investitor:	Virovitičko-podravaska županija, Trg Ljudevita Patačića 1, 33000 Virovitica OIB: 93362201007	glavni projektant:	Davor Mateković, dipl.ing.arh.	sadržaj:	
		projektant:	Davor Mateković, dipl.ing.arh.		
građevina:	Centar za kulturu zdravlja - Rekonstrukcija dvorca Janković u Cabuni	suradnici:	Tomislav Stojan, dipl.ing.arh., Nataša Mandir, mag.ing.arch.,	br. t.d.	07/14
lokacija:	k.č.br. 607/2 k.o. Cabuna			datum:	studen 2020.
faza:	IZVEDBENI PROJEKT	direktor:	Tomislav Stojan, dipl.ing.arh.	list:	



TLOCRT

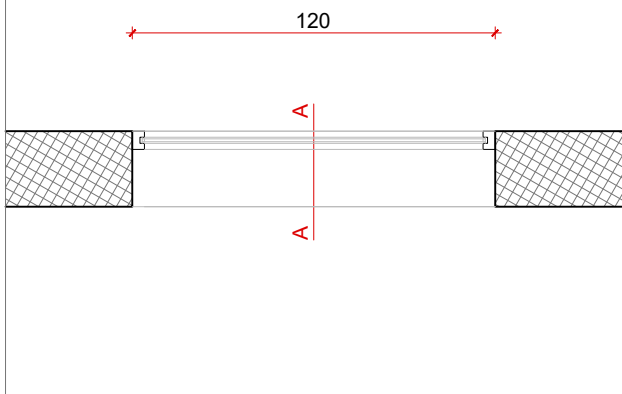

UNUTARNJA  
BRAVARIJA

ST. 16

FIKSNA PRAVOKUTNA STIJENA

120/240 cm kom: 7

POGLED

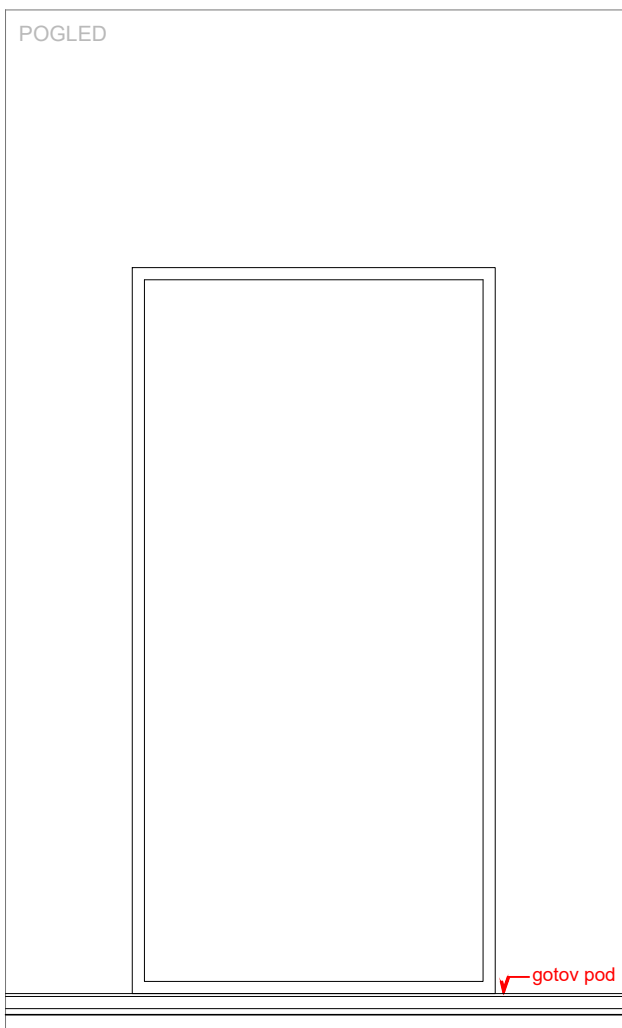

PRESJEK A-A

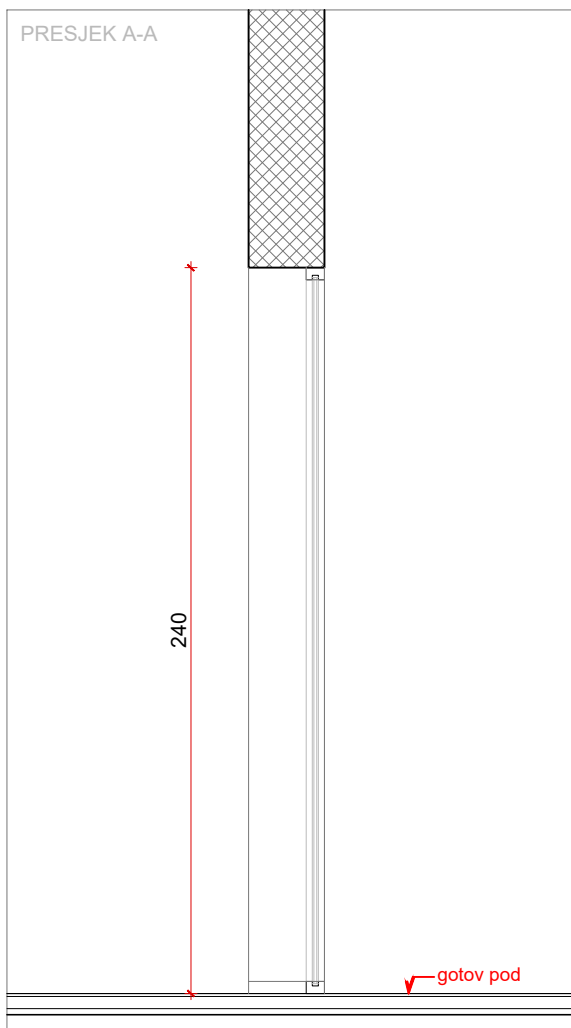

PROARH

Proarh mateković d.o.o.  
za arhitektonsko projektiranje

Kneza Mislava 15, Zagreb, 10000, Croatia  
t. +385 1 46 36 015, +385 1 46 36 002, f. + 385 1 45 52 878

investitor:	Virovitičko-podravska županija, Trg Ljudevita Patačića 1, 33000 Virovitica OIB: 93362201007	glavni projektant:	Davor Mateković, dipl.ing.arh.	sadržaj:	
građevina:	Centar za kulturu zdravlja - Rekonstrukcija dvorca Janković u Cabuni	projektant:	Davor Mateković, dipl.ing.arh.	br. t.d.	07/14
lokacija:	k.č.br. 607/2 k.o. Cabuna	suradnici:	Tomislav Stojan, dipl.ing.arh., Nataša Mandir, mag.ing.arch.,	datum:	studen 2020.
faza:	IZVEDBENI PROJEKT	direktor:	Tomislav Stojan, dipl.ing.arh.	list:	

TLOCRT

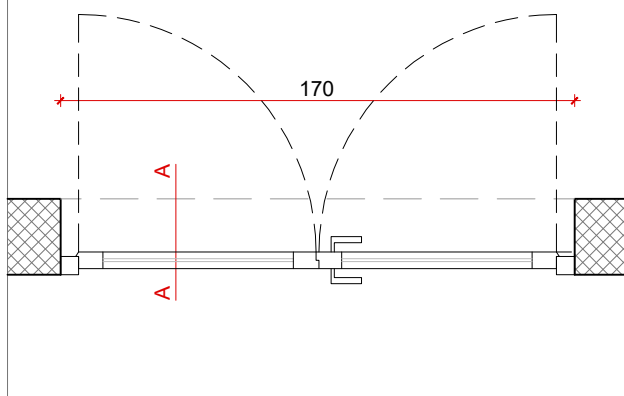
UNUTARNJA  
BRAVARIJA

ST. 17

OSTAKLJENA DVOKRILNA ZAOKRETNNA VRATA

170/220 cm kom: 1

POGLED

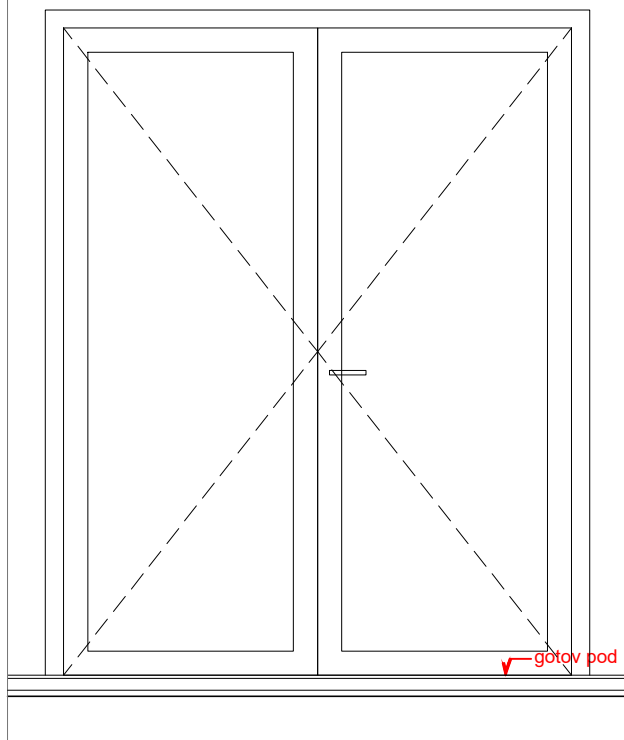

PRESJEK A-A

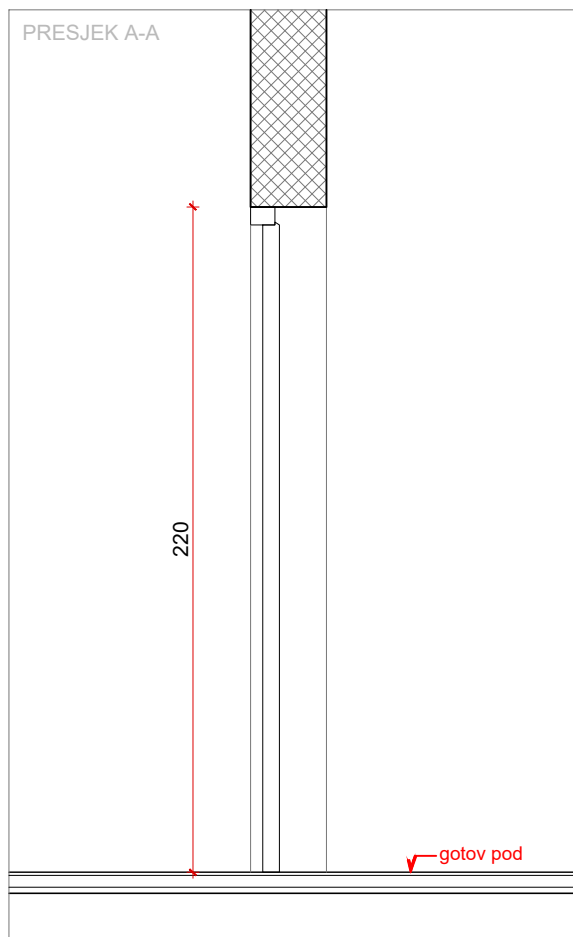

P R O A R H

Proarh mateković d.o.o.  
za arhitektonsko projektiranjeKneza Mislava 15, Zagreb, 10000, Croatia  
t. +385 1 46 36 015, +385 1 46 36 002, f. + 385 1 45 52 878

investitor: Virovitičko-podravska županija, Trg Ljudevita Patačića 1, 33000 Virovitica OIB: 93362201007	glavni projektant: Davor Mateković, dipl.ing.arh.	sadržaj: <b>SHEME BRAVARIJE</b> m 1:25
	projektant: Davor Mateković, dipl.ing.arh.	
građevina: Centar za kulturu zdravlja - Rekonstrukcija dvorca Janković u Cabuni	suradnici: Tomislav Stojan, dipl.ing.arh., Nataša Mandir, mag.ing.arch.,	br. t.d. 07/14
lokacija: k.č.br. 607/2 k.o. Cabuna		datum: studeni 2020.
faza: <b>IZVEDBENI PROJEKT</b>	direktor: Tomislav Stojan, dipl.ing.arh.	list:

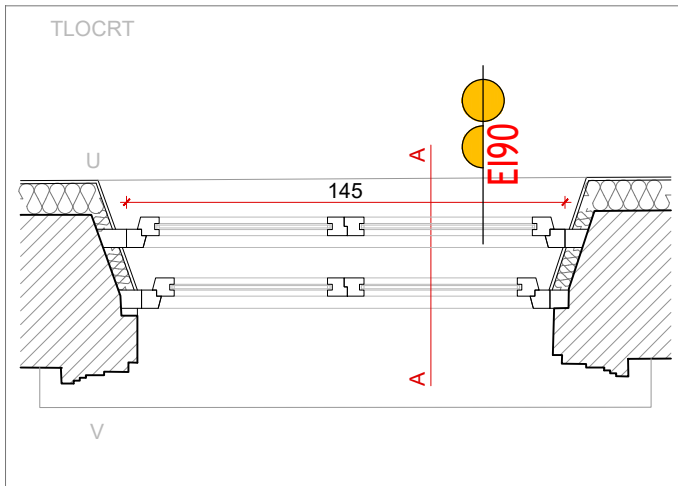

PP VANJSKA  
BRAVARIJA

ST. 23

DVOKRILNI ZAOKRETNO-OTKLOPNI PROZOR S  
ZAOKRETNO-OTKLOPNIM NADSVJETLOM  
UGRADBA U POSTOJEĆI ZID OD OPEKE

145/210 cm kom: 1

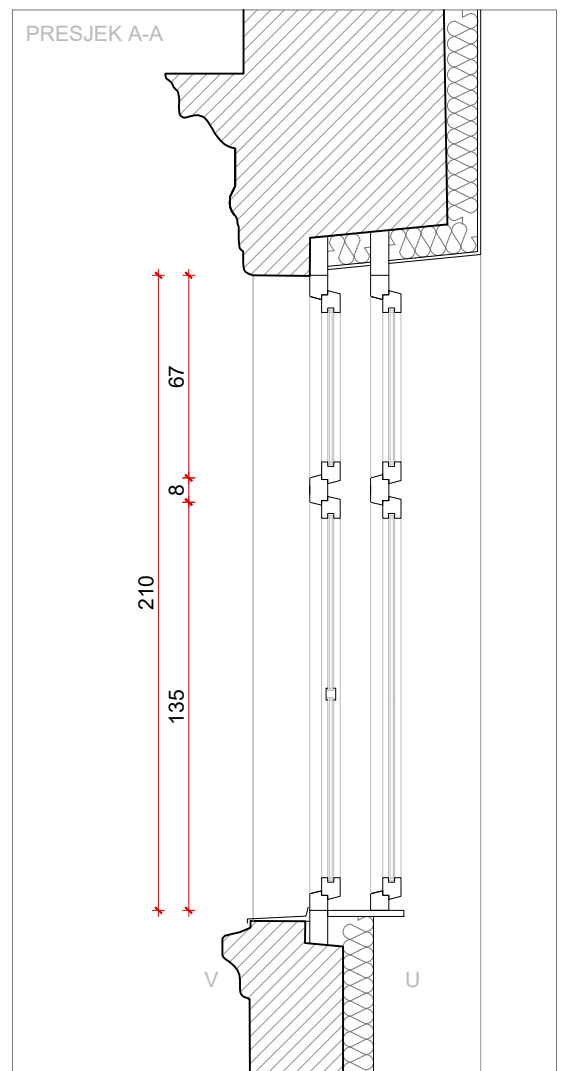
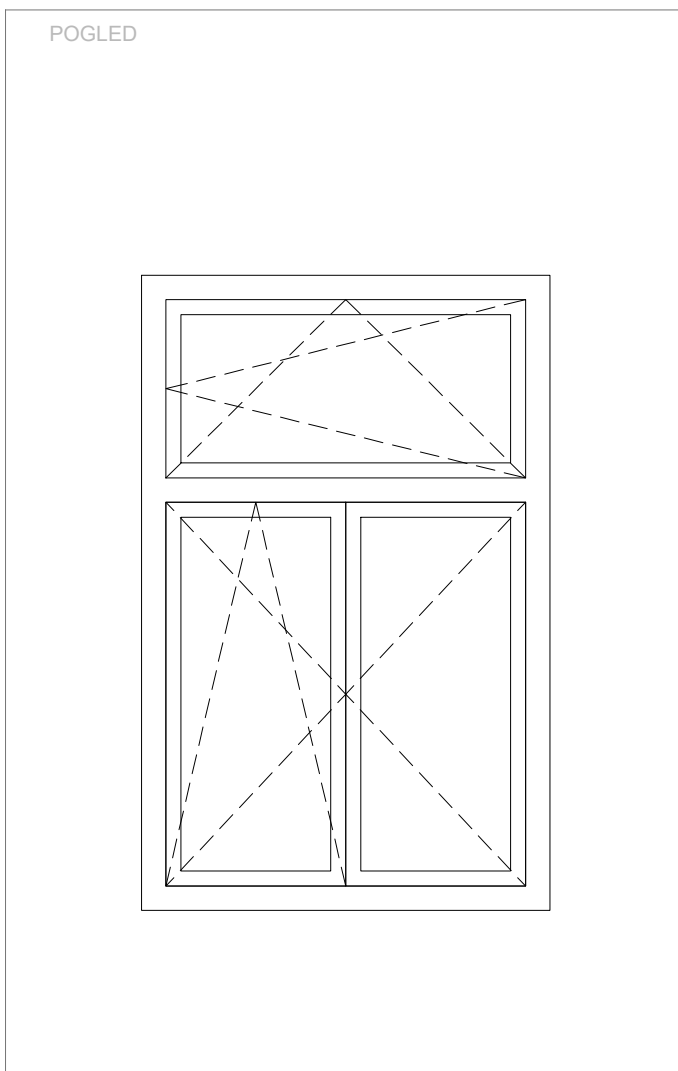

PROARH

Proarh mateković d.o.o.  
za arhitektonsko projektiranje

Kneza Mislava 15, Zagreb, 10000, Croatia  
t. +385 1 46 36 015, +385 1 46 36 002, f. + 385 1 45 52 878

investitor:	Virovitičko-podravka županija, Trg Ljudevita Patačića 1, 33000 Virovitica OIB: 93362201007	glavni projektant:	Davor Mateković, dipl.ing.arh.	sadržaj:	SHEME STOLARIJE m 1:25
	građevina:	Centar za kulturu zdravlja - Rekonstrukcija dvorca Janković u Cabuni	projektant:		
lokacija:	k.č.br. 607/2 k.o. Cabuna	suradnici:	Tomislav Stojan, dipl.ing.arh., Nataša Mandir, mag.ing.arch.,	br. t.d.	07/14
faza:	IZVEDBENI PROJEKT	direktor:	Tomislav Stojan, dipl.ing.arh.	datum:	studeni 2020.
				list:	

TLOCRT

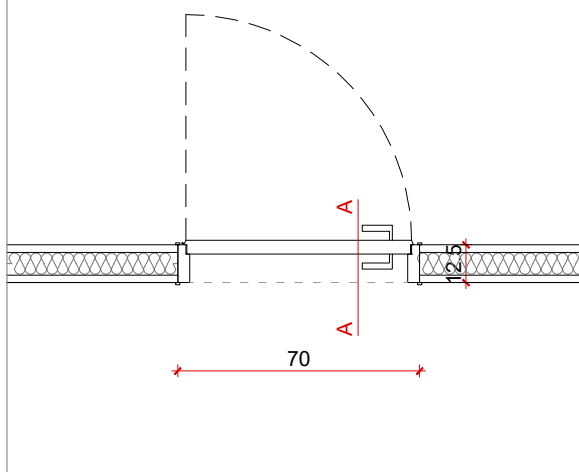

UNUTARNJA  
STOLARIJA

ST. 01

PUNA JEDNOKRILNA ZAOKRETNA VRATA  
UGRADBA U ZID OD GIPSKARTONA d=12,5 cm

80/220 cm kom: L= 1  
D= 1  
70/220 kom: L=1

POGLED

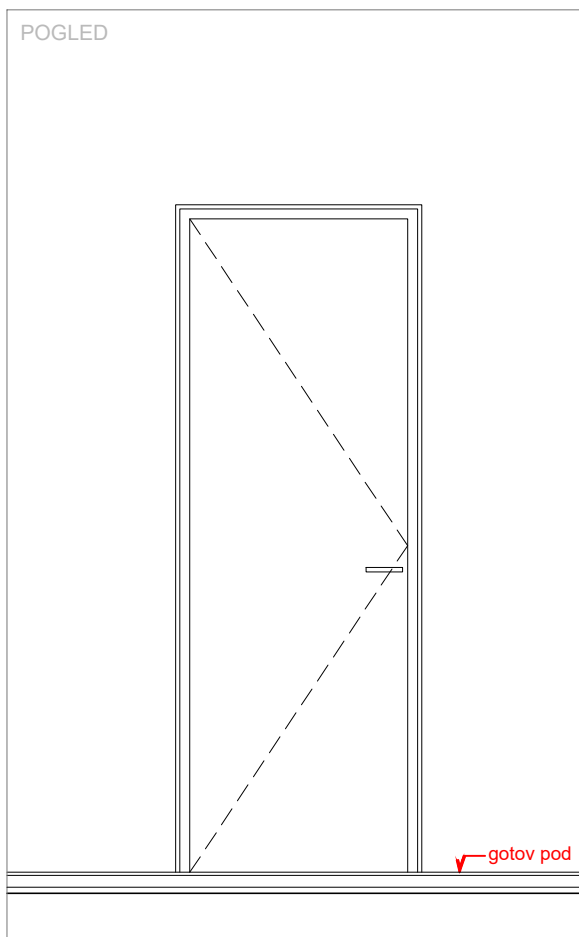

PRESJEK A-A

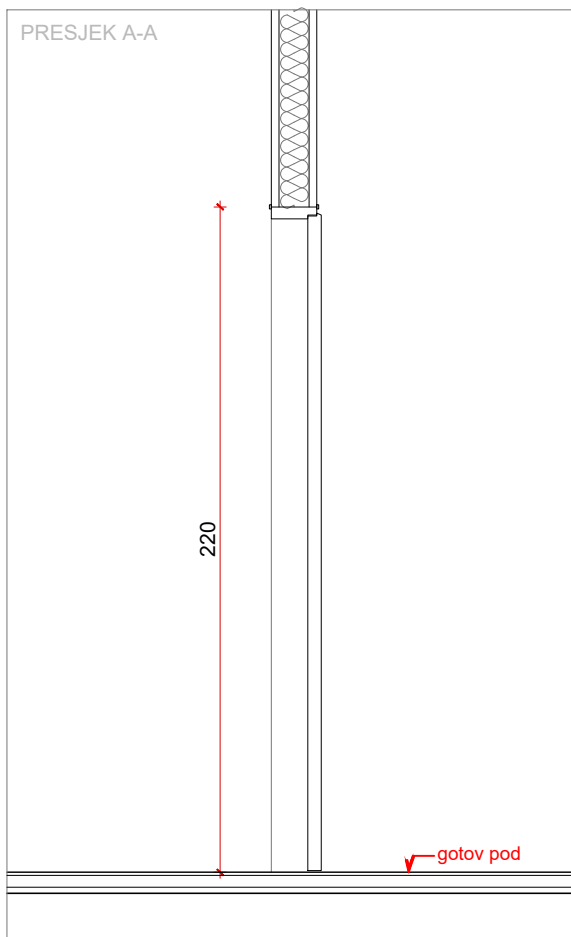

PROARH

Proarh mateković d.o.o.  
za arhitektonsko projektiranje

Kneza Mislava 15, Zagreb, 10000, Croatia  
t. +385 1 46 36 015, +385 1 46 36 002, f. + 385 1 45 52 878

investitor: Virovitičko-podravska županija, Trg Ljudevita Patačića 1, 33000 Virovitica OIB: 93362201007	glavni projektant: Davor Mateković, dipl.ing.arh.	sadržaj: <b>SHEME STOLARIJE</b> m 1:25
	projektant: Davor Mateković, dipl.ing.arh.	
građevina: Centar za kulturu zdravlja - Rekonstrukcija dvorca Janković u Cabuni	suradnici: Tomislav Stojan, dipl.ing.arh., Nataša Mandir, mag.ing.arch.,	br. t.d. 07/14
lokacija: k.č.br. 607/2 k.o. Cabuna		datum: studeni 2020.
faza: <b>IZVEDBENI PROJEKT</b>	direktor: Tomislav Stojan, dipl.ing.arh.	list:

TLOCRT

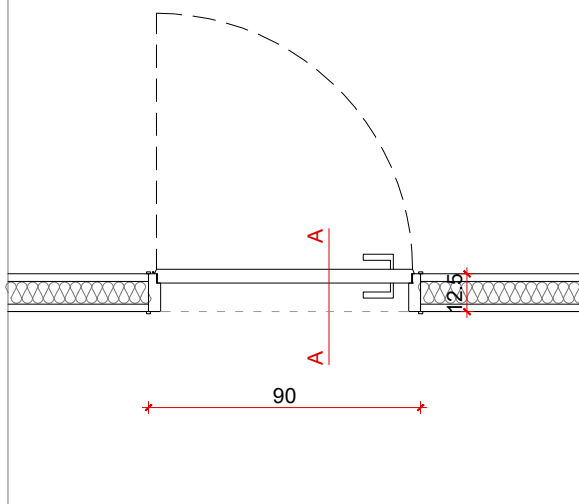
UNUTARNJA  
STOLARIJA

ST. 02

PUNA JEDNOKRILNA ZAOKRETNA VRATA  
UGRADBA U ZID OD GIPSKARTONA d=12,5 cm90/250 cm kom: L= 1  
D= 190/220 cm kom: L= 1  
D= 2

POGLED

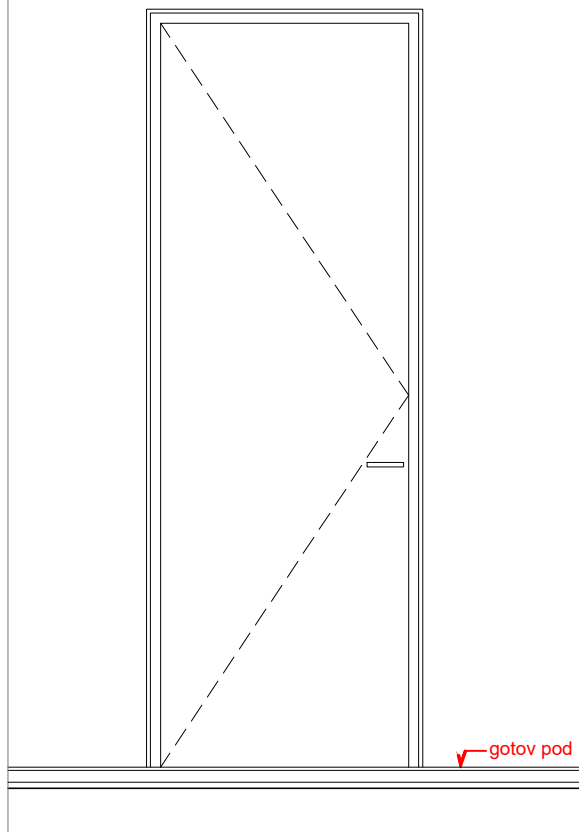

PRESJEK A-A

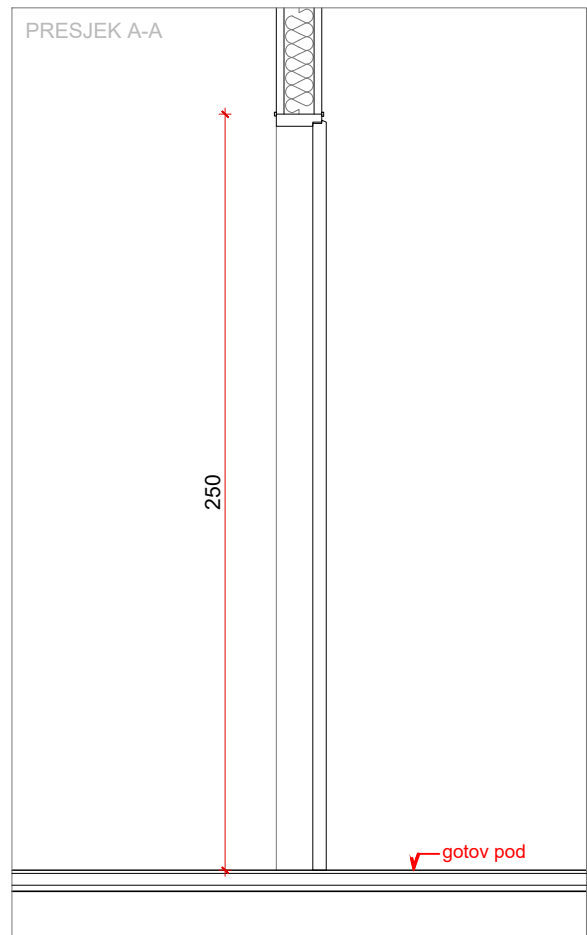

P R O A R H

Proarh mateković d.o.o.  
za arhitektonsko projektiranjeKneza Mislava 15, Zagreb, 10000, Croatia  
t. +385 1 46 36 015, +385 1 46 36 002, f. + 385 1 45 52 878

investitor: Virovitičko-podravka županija, Trg Ljudevita Patačića 1, 33000 Virovitica OIB: 93362201007	glavni projektant: Davor Mateković, dipl.ing.arh.	sadržaj: <b>SHEME STOLARIJE</b> m 1:25
	projektant: Davor Mateković, dipl.ing.arh.	
građevina: Centar za kulturu zdravlja - Rekonstrukcija dvorca Janković u Cabuni	suradnici: Tomislav Stojan, dipl.ing.arh., Nataša Mandir, mag.ing.arch.,	br. t.d. 07/14
lokacija: k.č.br. 607/2 k.o. Cabuna		datum: studeni 2020.
faza: <b>IZVEDBENI PROJEKT</b>	direktor: Tomislav Stojan, dipl.ing.arh.	list:

TLOCRT

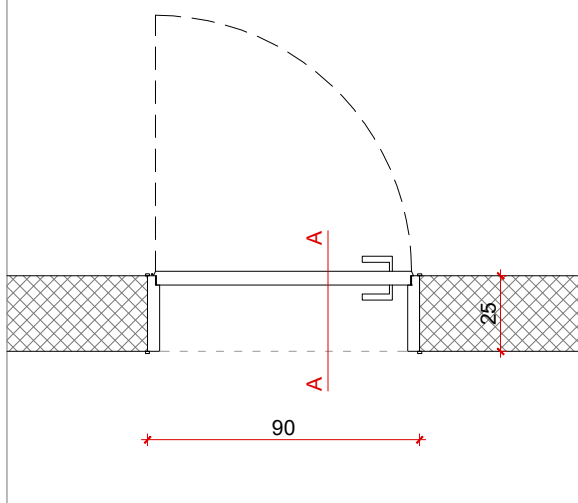

UNUTARNJA  
STOLARIJA

ST. 03

PUNA JEDNOKRILNA ZAOKRETNA VRATA

UGRADBA U ZID OD ARMIRANOG BETONA d=25 cm

90/220 cm

kom: D=3

POGLED

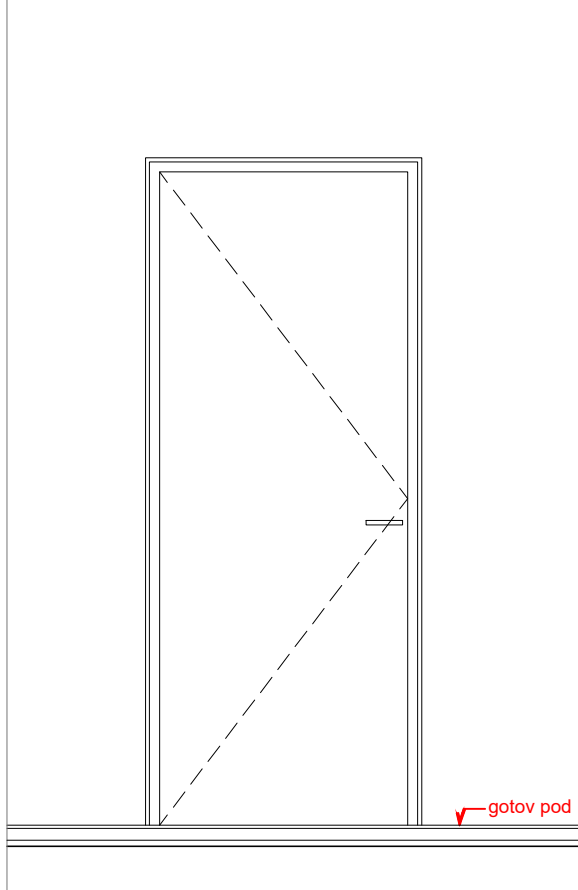

PRESJEK A-A

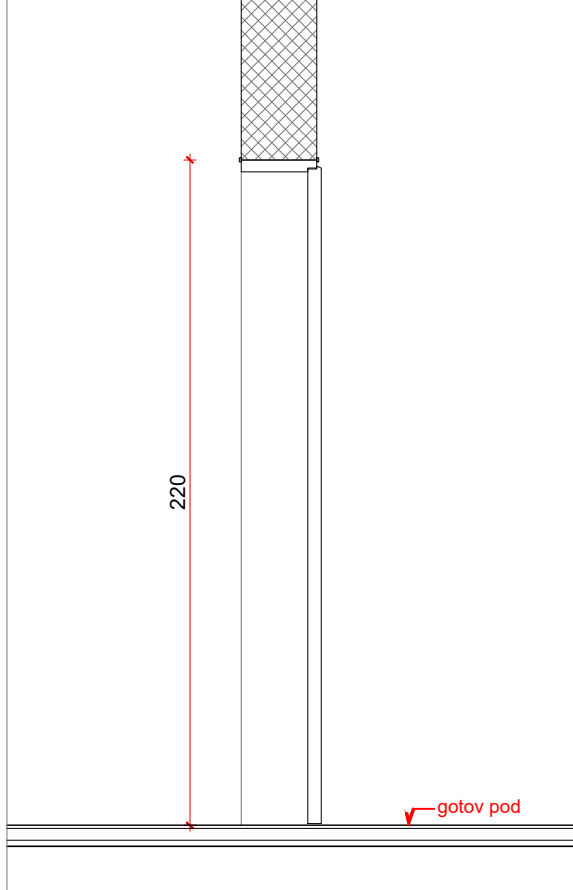

PROARH

Proarh mateković d.o.o.  
za arhitektonsko projektiranje

Kneza Mislava 15, Zagreb, 10000, Croatia  
t. +385 1 46 36 015, +385 1 46 36 002, f. + 385 1 45 52 878

investitor: Virovitičko-podravka županija, Trg Ljudevita Patačića 1, 33000 Virovitica OIB: 93362201007	glavni projektant: Davor Mateković, dipl.ing.arh.	sadržaj: <b>SHEME STOLARIJE</b> m 1:25
	projektant: Davor Mateković, dipl.ing.arh.	
građevina: Centar za kulturu zdravlja - Rekonstrukcija dvorca Janković u Cabuni	suradnici: Tomislav Stojan, dipl.ing.arh., Nataša Mandir, mag.ing.arch.,	br. t.d. 07/14
lokacija: k.č.br. 607/2 k.o. Cabuna		datum: studeni 2020.
faza: <b>IZVEDBENI PROJEKT</b>	direktor: Tomislav Stojan, dipl.ing.arh.	list:

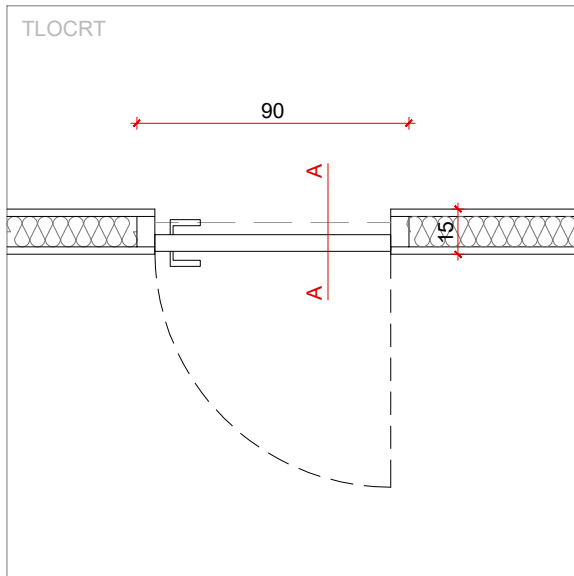

UNUTARNJA  
STOLARIJA

ST. 4

PUNA JEDNOKRILNA ZAOKRETNNA VRATA SA  
SKRIVENIM ŠTOKOM  
UGRADBA U ZID OD GIPSKARTONA d=15 cm, d=12,5  
cm

90/250 cm D=2

100/220 cm L=1

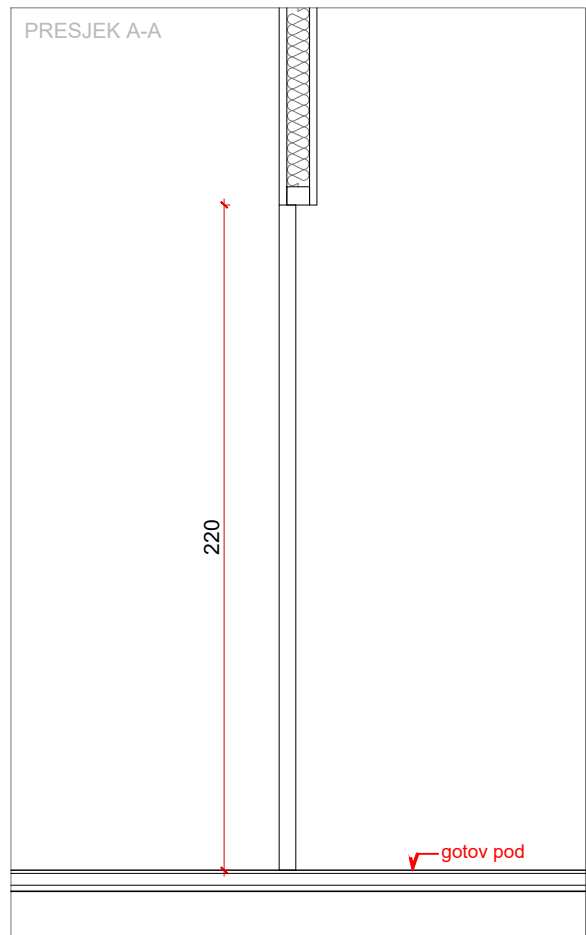
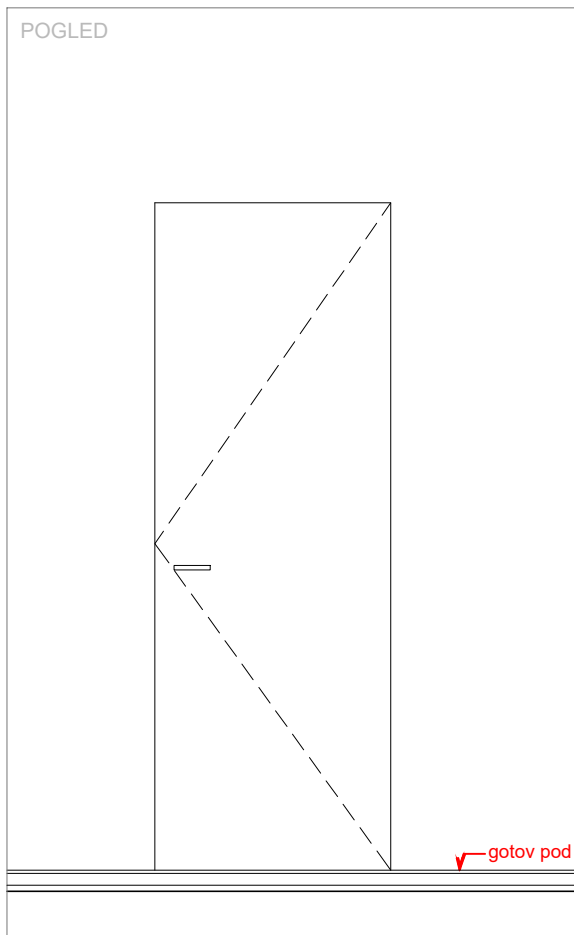

PROARH

Proarh mateković d.o.o.  
za arhitektonsko projektiranje

Kneza Mislava 15, Zagreb, 10000, Croatia  
t. +385 1 46 36 015, +385 1 46 36 002, f. + 385 1 45 52 878

investitor: Virovitičko-podravška županija, Trg Ljudevita Patačića 1, 33000 Virovitica OIB: 93362201007	glavni projektant: Davor Mateković, dipl.ing.arh.	sadržaj: <b>SHEME STOLARIJE</b> m 1:25
	projektant: Davor Mateković, dipl.ing.arh.	
građevina: Centar za kulturu zdravlja - Rekonstrukcija dvorca Janković u Cabuni	suradnici: Tomislav Stojan, dipl.ing.arh., Nataša Mandir, mag.ing.arch.,	br. t.d. 07/14
lokacija: k.č.br. 607/2 k.o. Cabuna		datum: studeni 2020.
faza: <b>IZVEDBENI PROJEKT</b>	direktor: Tomislav Stojan, dipl.ing.arh.	list:

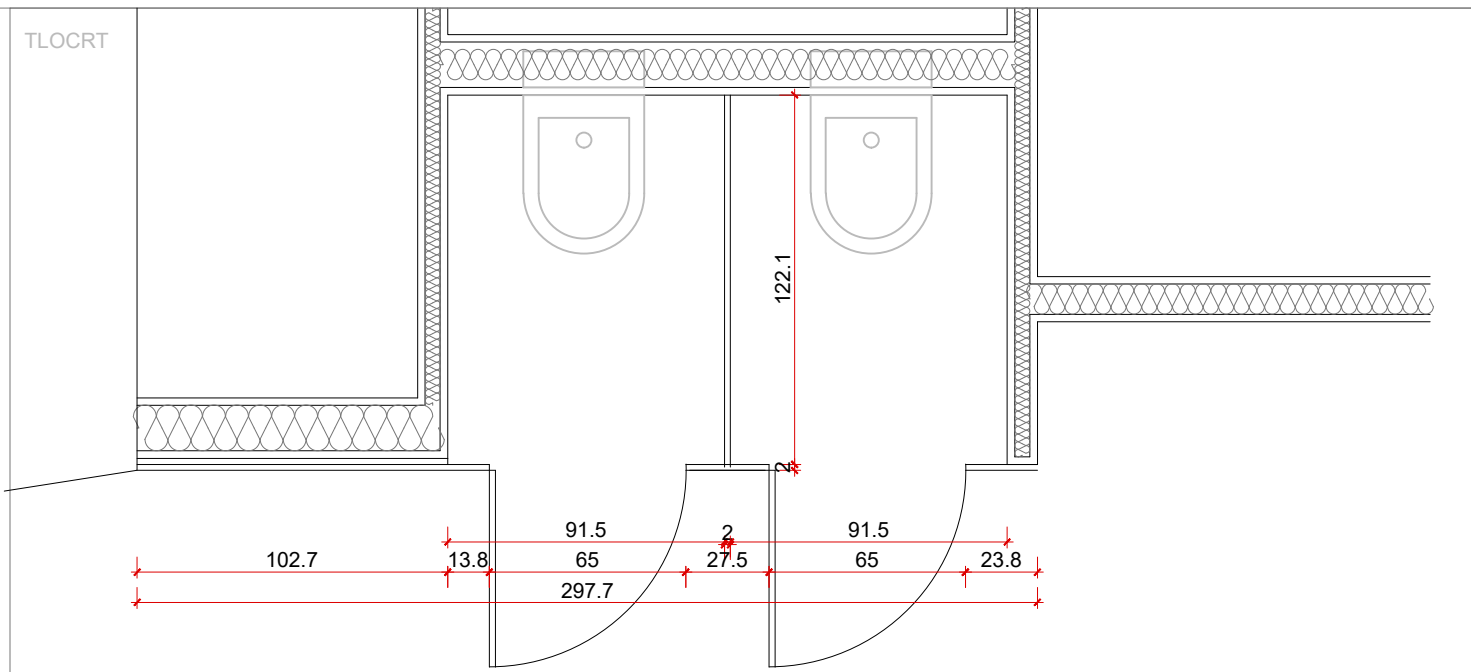

UNUTARNJA  
STOLARIJA

ST. 5a

PREGRADE WC-A OD VODOOTPORNH VISOKOTLAČNO PREŠANIH LAMINAT PLOČA (HPL) SA DVA JEDNOKRILNA ZAOKRETNNA VRATA DIM. 65/200 cm. MONTIRAJU SE NA POTKONSTRUKCIJU PRIČVRŠČENU NA KNAUF ZID.

ukupna dimenzija : 298 x 400 cm  
vrata: 2x 65x210 cm

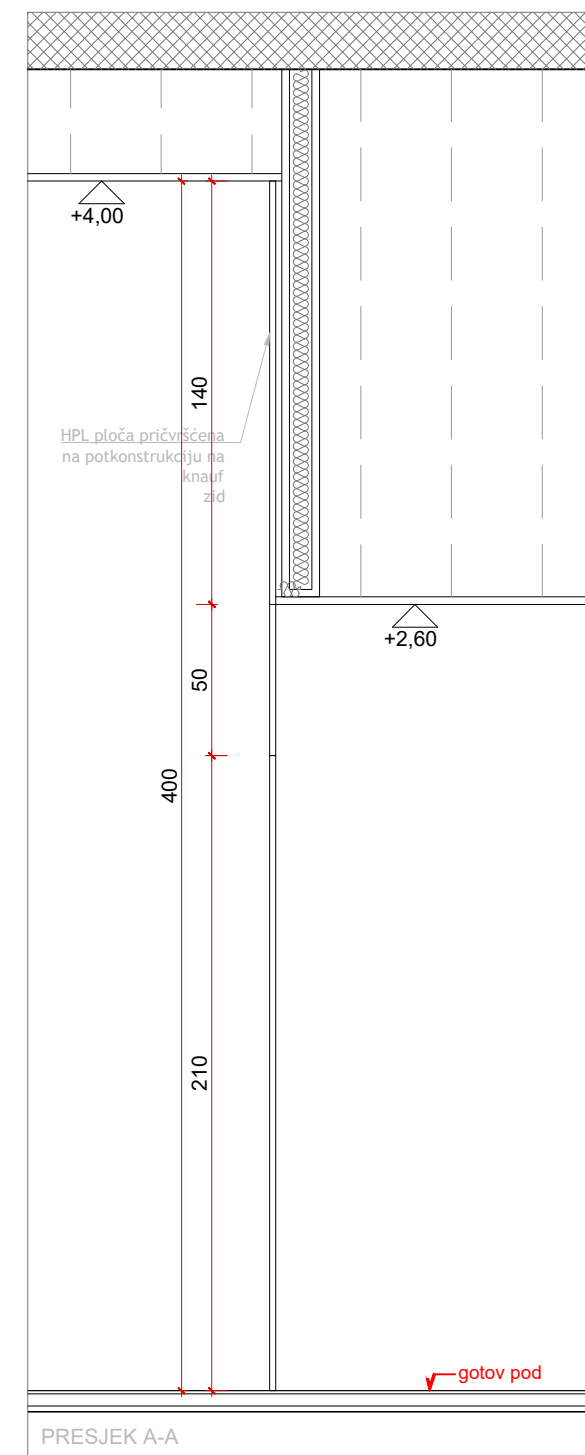
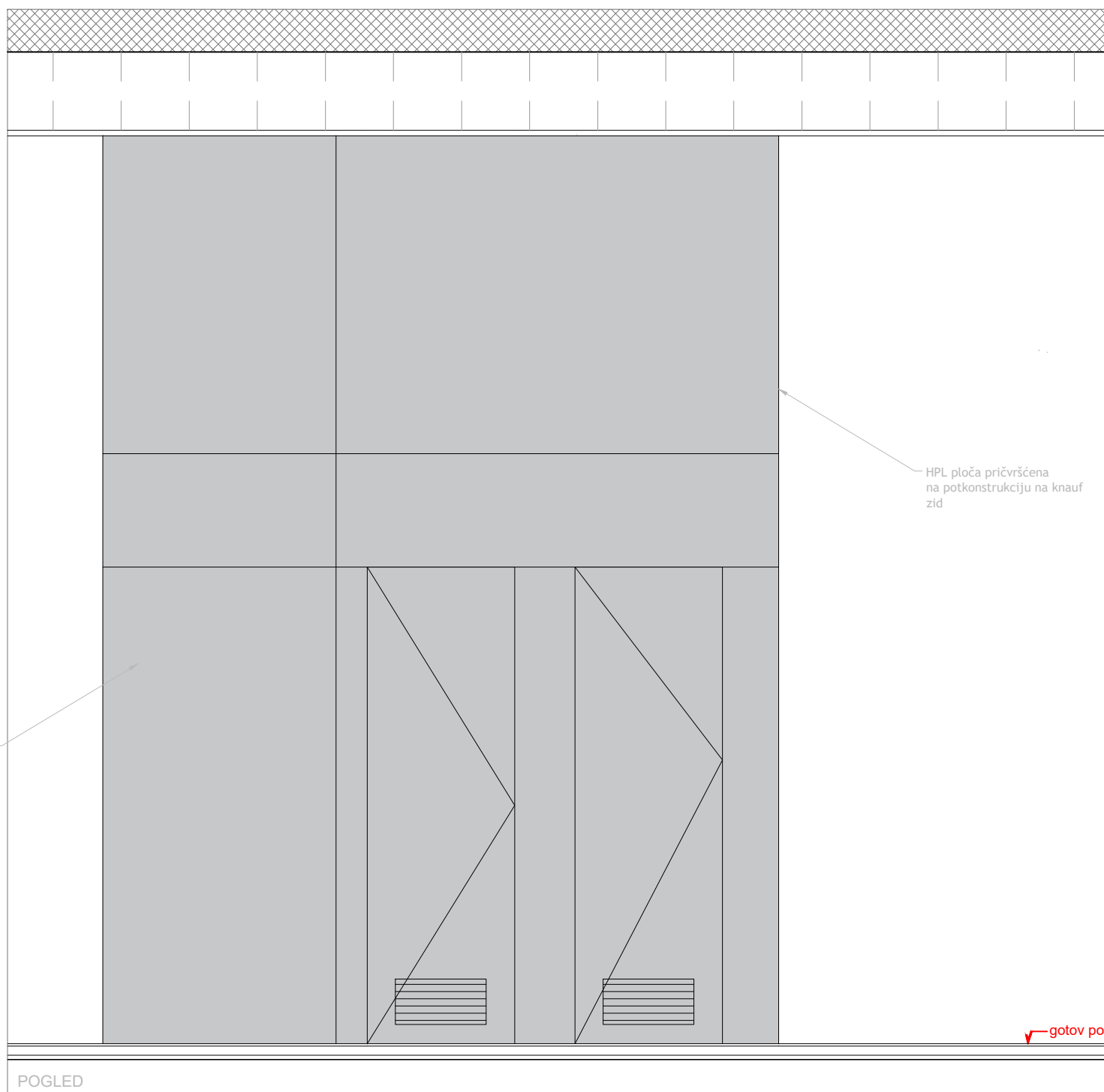

PROARRH  
Proarrh mateković d.o.o.  
Kneza Mislava 15, Zagreb, 10000, Croatia  
t. +385 1 46 36 015, +385 1 46 36 002, f. + 385 1 45 52 878

za arhitektonsko projektiranje

investitor:  
Virovitičko-podravsko županijska  
Trg Ljudevita Patačića 1, 33000 Virovitica  
OIB: 93362201007

gradjevina:  
Centar za kulturu zdravlja -  
Rekonstrukcija dvorca Janković u Cabuni

glavni projektant: Davor Mateković, dipl.ing.arh.	sadržaj: SHEME BRAVARIJE
projektant: Davor Mateković, dipl.ing.arh.	br. t.d. 07/14
suradnici: Tomislav Štojan, dipl.ing.arh., Nataša Mandir, mag.ing.arch.,	datum: studeni 2020.
direktor: Tomislav Štojan, dipl.ing.arh.	list:

faza:  
IZVEDBENI PROJEKT

POGLED

PRESJEK A-A



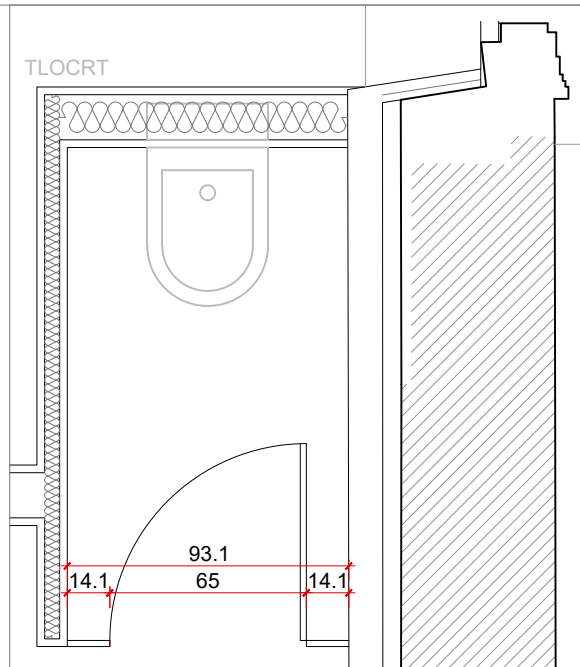

**UNUTARNJA STOLARIJA ST. 05b**

PREGRADE WC-A OD VODOOTPORNIH VISOKOTLAČNO PREŠANIH LAMINAT PLOČA (HPL) JEDNOKRILNIM ZAOKRETNIM VRATIMA DIM. 65/200 cm. MONTIRAJU SE NA ALU NOSAČE ODIGNUTE OD PODA 15 cm.

ukupna dimenzija: 93,1 x 400 cm  
vrata: 1 x 65 x 210 cm

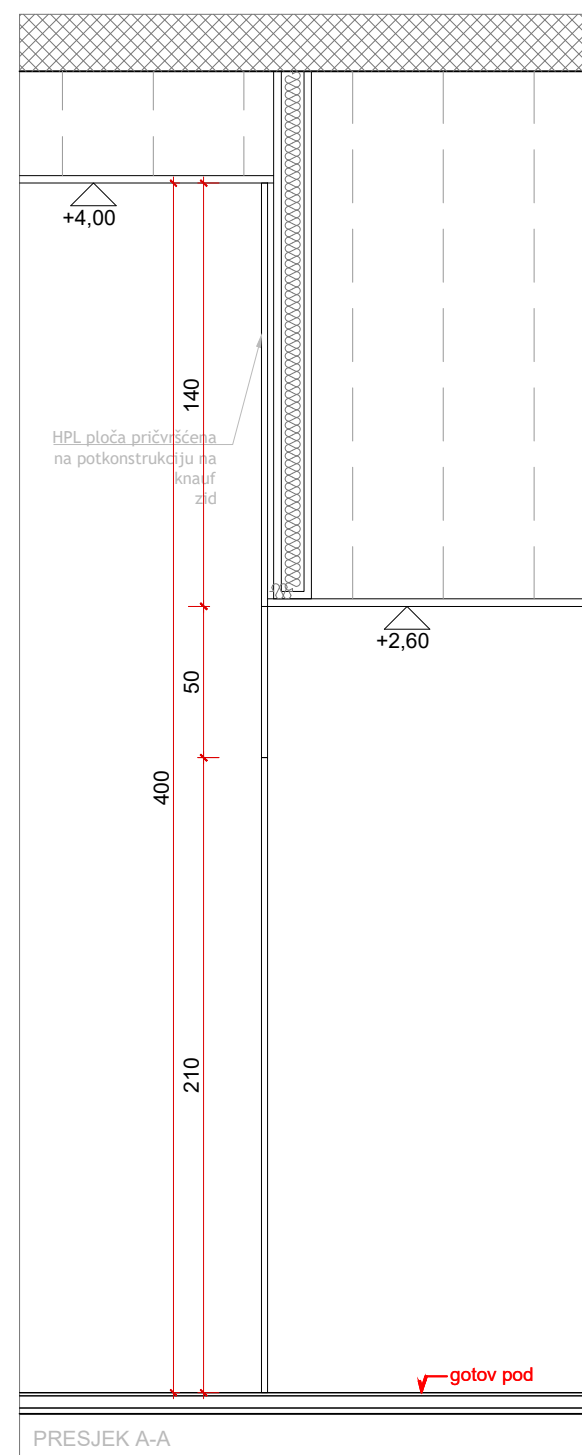
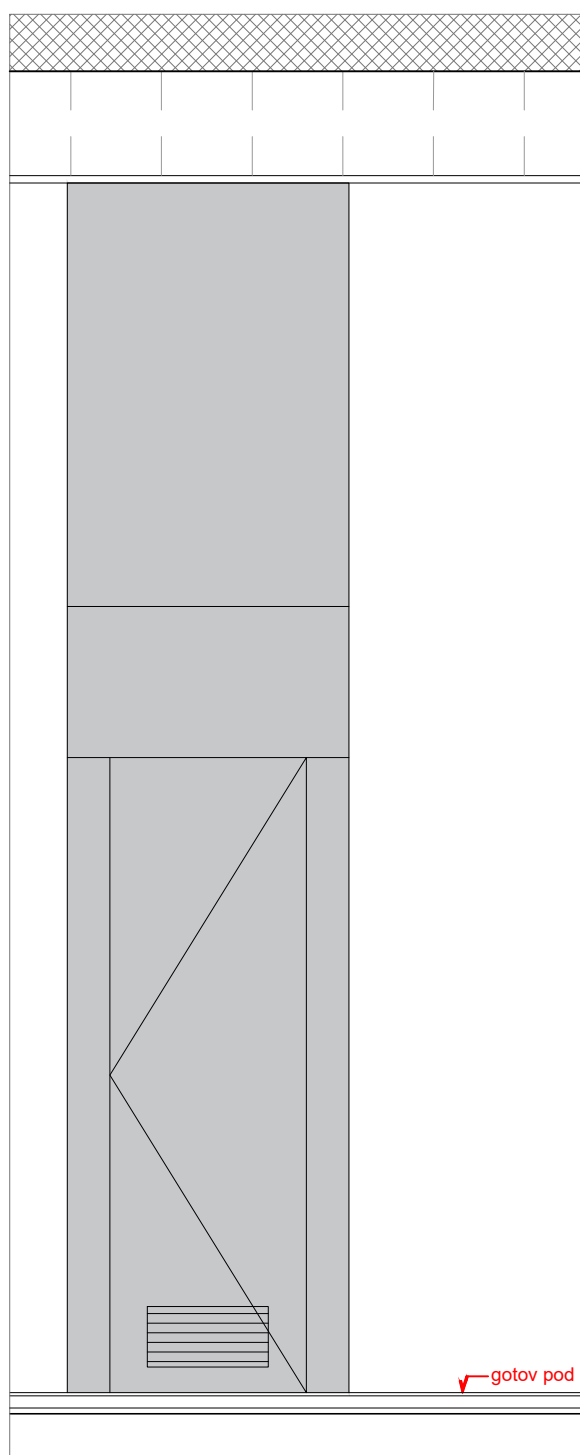

**PROARH** Proarh mateković d.o.o. Kneza Mislava 15, Zagreb, 10000, Croatia  
za arhitektonsko projektiranje t. +385 1 46 36 015, +385 1 46 36 002, f. + 385 1 45 52 878

investitor:	Virovitičko-podavska županija, Trg Ljudevita Patačića 1, 33000 Virovitica OIB: 93362201007	glavni projektant:	Davor Mateković, dipl.ing.arh.	sadržaj:	<b>HEME BRAVARIJE</b> m 1:25
gradevina:	Centar za kulturu zdravlja - Rekonstrukcija dvorca Janković u Cabuni	projektant:	Davor Mateković, dipl.ing.arh.	br. t.d.	07/14
lokacija:	k.č.br. 607/2 k.o. Cabuna	suradnici:	Tomislav Stojan, dipl.ing.arh., Nataša Mandir, mag.ing.arch.	datum:	studenj 2020.
faza:	<b>IZVEDBENI PROJEKT</b>	direktor:	Tomislav Stojan, dipl.ing.arh.	list:	

TLOCRT

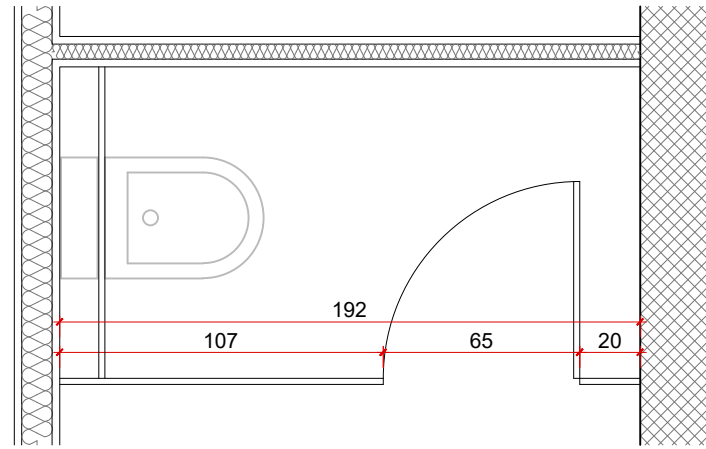

UNUTARNJA  
STOLARIJA

ST. 5c

PREGRADE WC-A OD VODOOTPORNIH VISOKOTLAČNO  
PREŠANIH LAMINAT PLOČA (HPL) JEDNOKRILNIM  
ZAOKRETNIM VRATIMA DIM. 65/200 cm. MONTIRAJU SE NA  
ALU NOSAČE ODIGNUTE OD PODA 15 cm.

ukupna dimenzija: 192 x 400 cm

vrata: 65 x 210 cm

POGLED

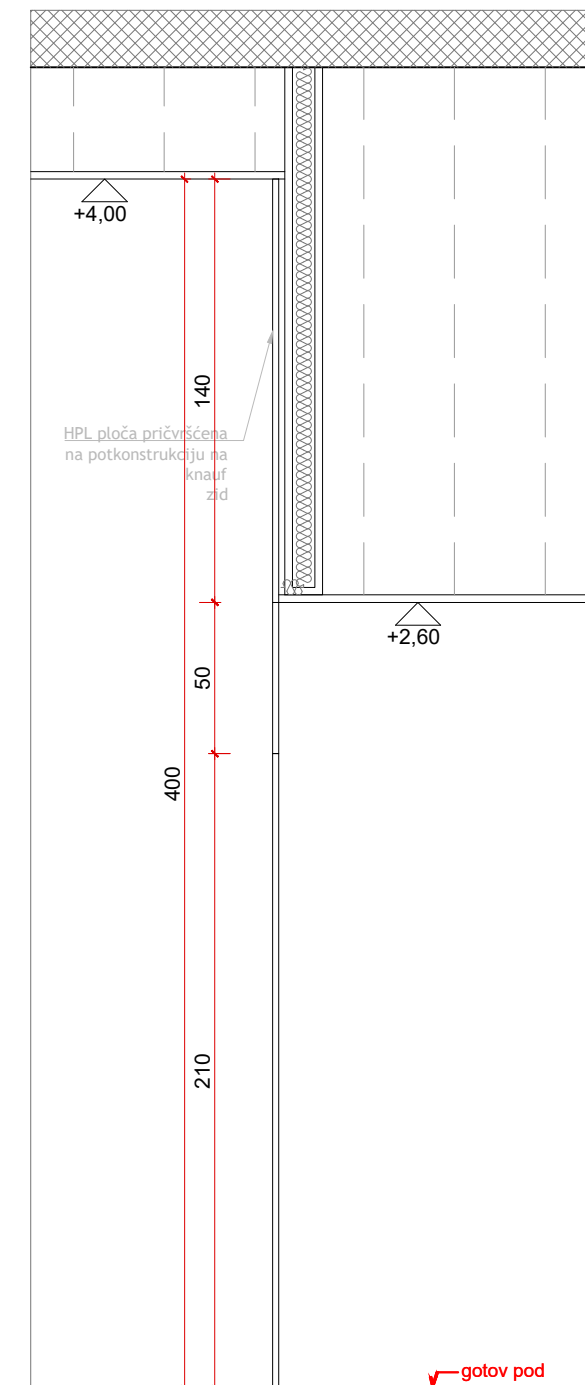
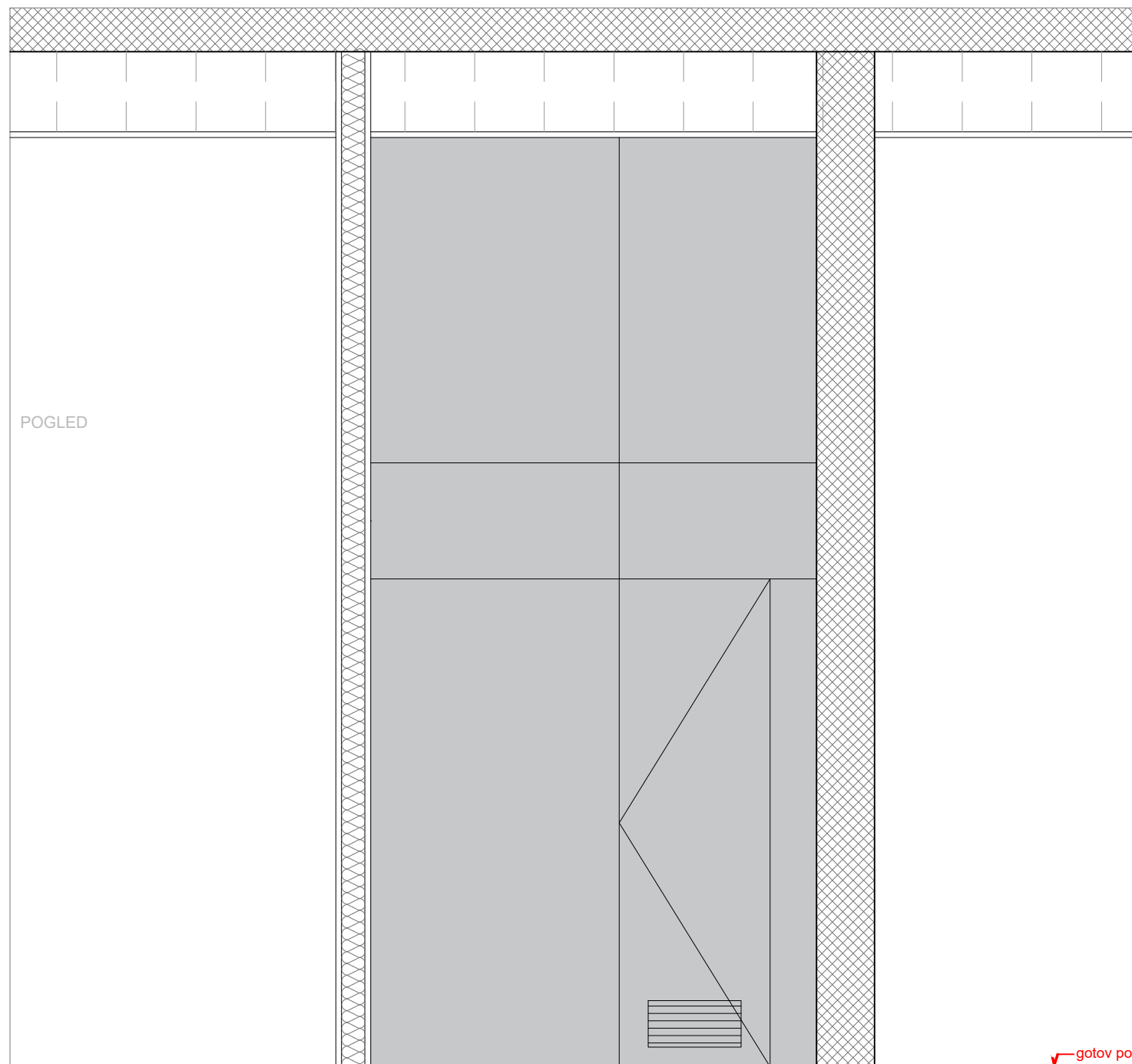

PRESJEK A-A

**PROARRH** Proarrh mateković d.o.o.  
za arhitektonsko projektiranje Kneza Mislava 15, Zagreb, 10000, Croatia  
t. +385 1 46 36 015, +385 1 46 36 002, f. + 385 1 45 52 878

investitor: Virovitičko-podravsko županija,  
Trg Ljudevita Patačića 1, 33000 Virovitica  
OIB: 9336201007

gradjevina: Centar za kulturu zdravlja -  
Rekonstrukcija dvorca Janjčević u Cabuni  
lokacija: k.č.br. 607/2 k.o. Cabuna

faza: IZVEDBENI PROJEKT

glavni projektant: <b>DŠTAR</b> Mateković, dipl.ing.arh.	sadržaj:
projektant: <b>BRVARIJE</b> Davor Mateković, dipl.ing.arh.	
suradnici: Tomislav Štojan, dipl.ing.arh., Nataša Mandir, mag.ing.arch.,	br. t.d. 07/14
	datum: studeni 2020.
direktor: Tomislav Štojan, dipl.ing.arh.	list:



TLOCRT

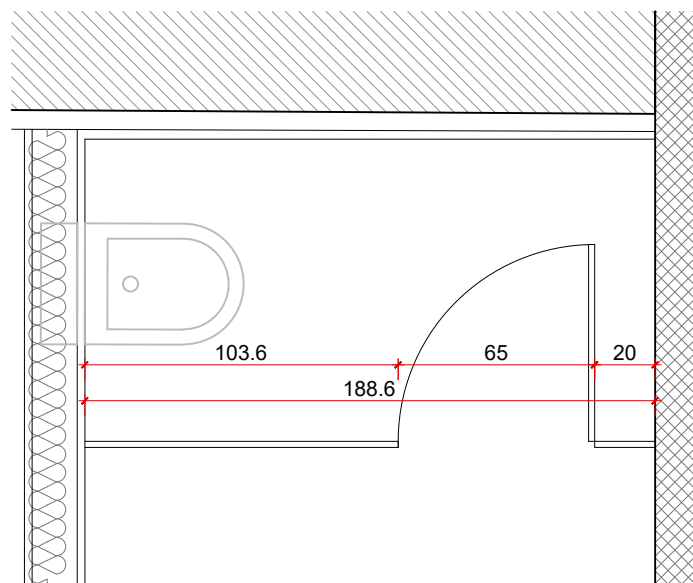

UNUTARNJA  
STOLARIJA

ST. 5e

PREGRADE WC-A OD VODOOTPORNIH VISOKOTLAČNO  
PREŠANIH LAMINAT PLOČA (HPL) JEDNOKRILNIM  
ZAKRETNIM VRATIMA DIM. 65/200 cm. MONTIRAJU SE NA  
ALU NOSAČE ODIGNUTE OD PODA 15 cm.

65/200+ fiksno 103.6+20 cm kompl: 1

POGLED

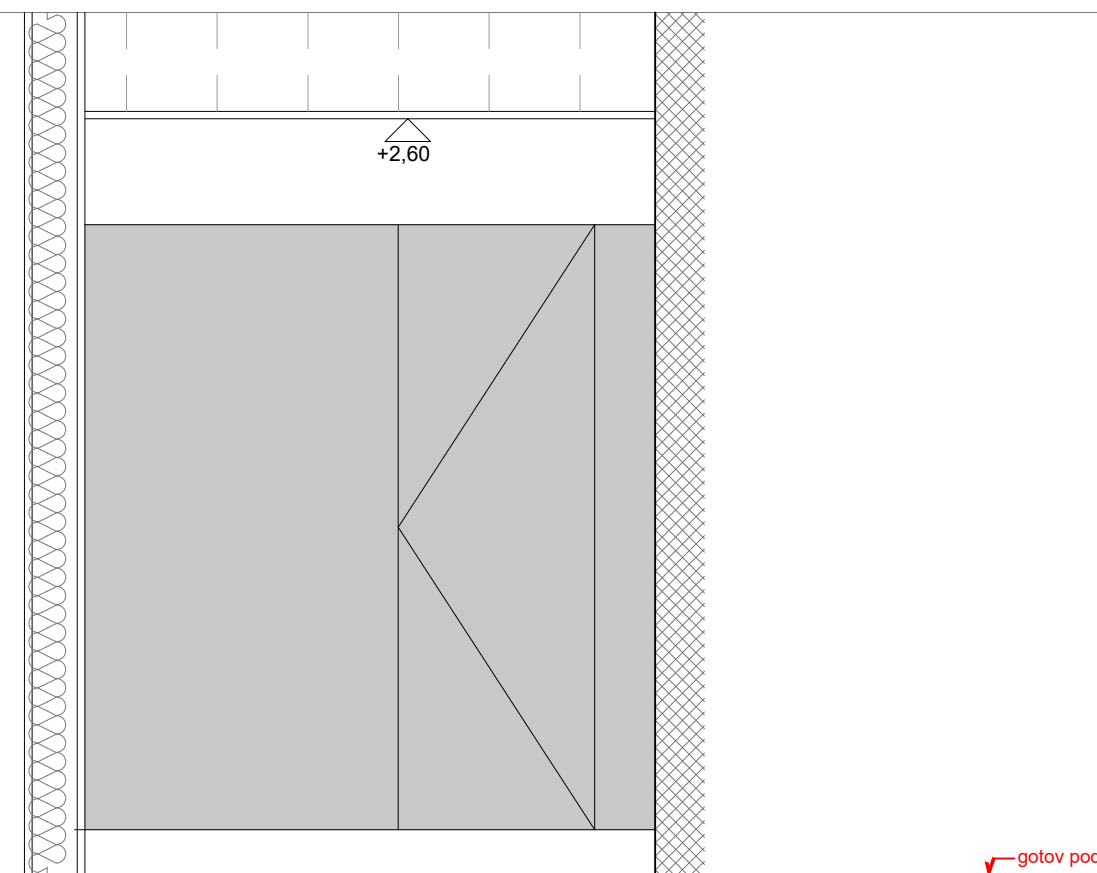

PRESEJAK A-A

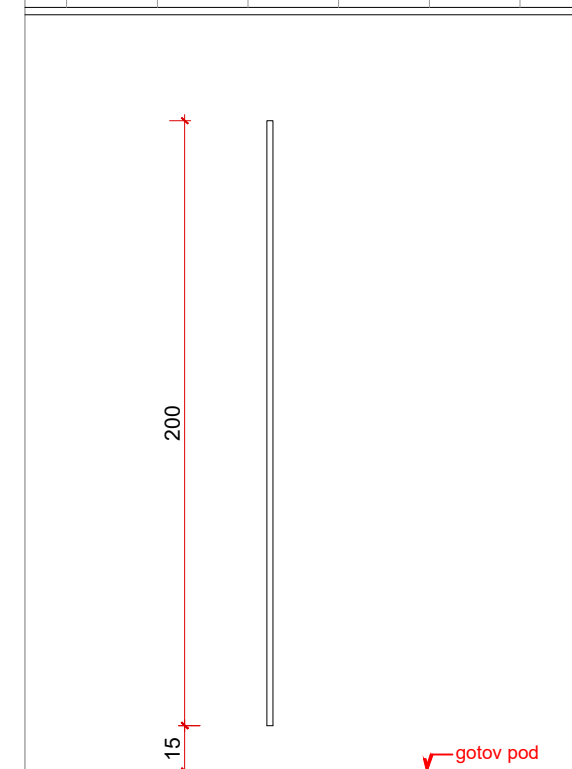

**PROARH** Proarh mateković d.o.o.  
za arhitektonsko projektiranje

Kneza Mislava 15, Zagreb, 10000, Croatia  
t. +385 1 46 36 015, +385 1 46 36 002, f. + 385 1 45 52 878

investitor: Virovitičko-podravska županija, Trg Ljudevita Patačića 1, 33000 Virovitica OIB: 93362201007	glavni projektant: Davor Mateković, dipl.ing.arh. projektant: Davor Mateković, dipl.ing.arh.	sadržaj: <b>HEME BRAVARIJE</b> m 1:25
gradjevina: Centar za kulturu zdravlja - Rekonstrukcija dvorca Janković u Cabuni	suradnici: Tomislav Stojan, dipl.ing.arh., Nataša Mandir, mag.ing.arch.,	br. t.d. 07/14
lokacija: k.č.br. 607/2 k.o. Cabuna	direktor: Tomislav Stojan, dipl.ing.arh.	datum: studeni 2020.
faza: <b>IZVEDBENI PROJEKT</b>	list:	

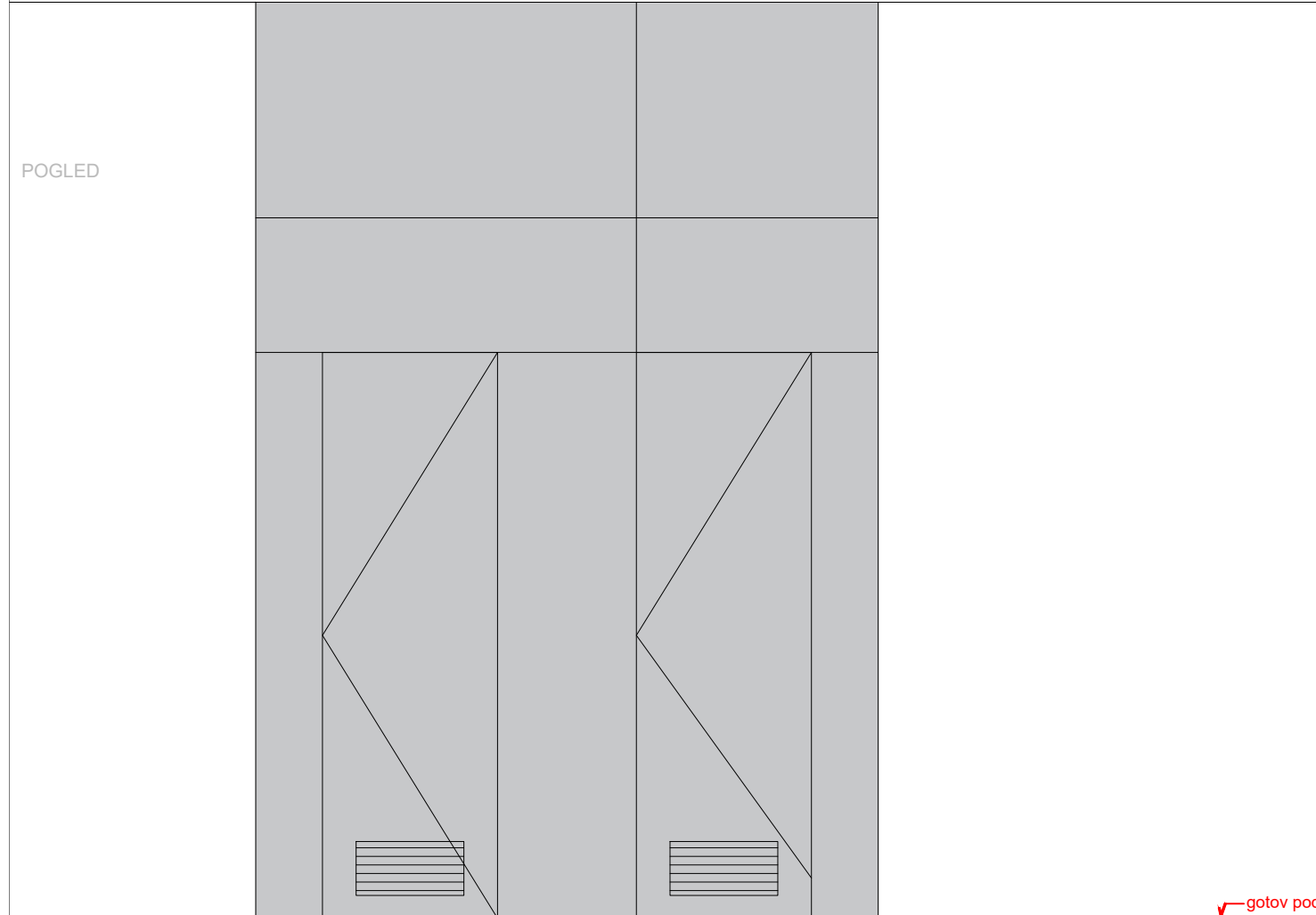
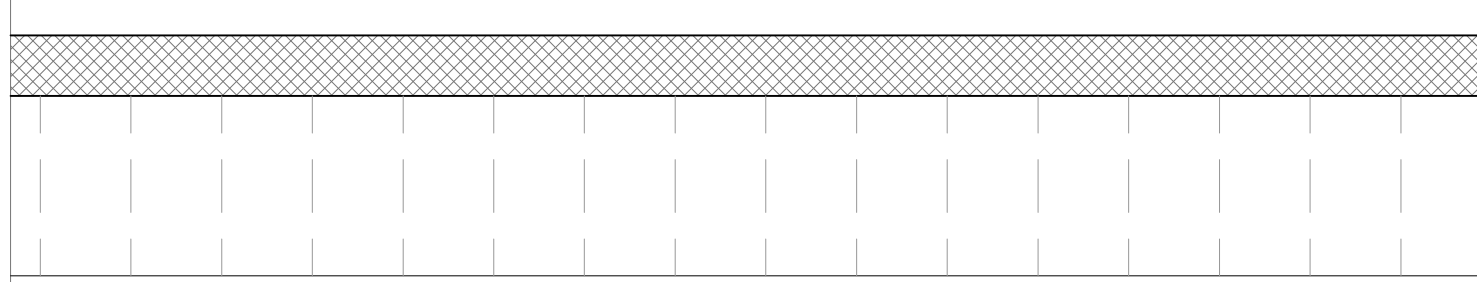
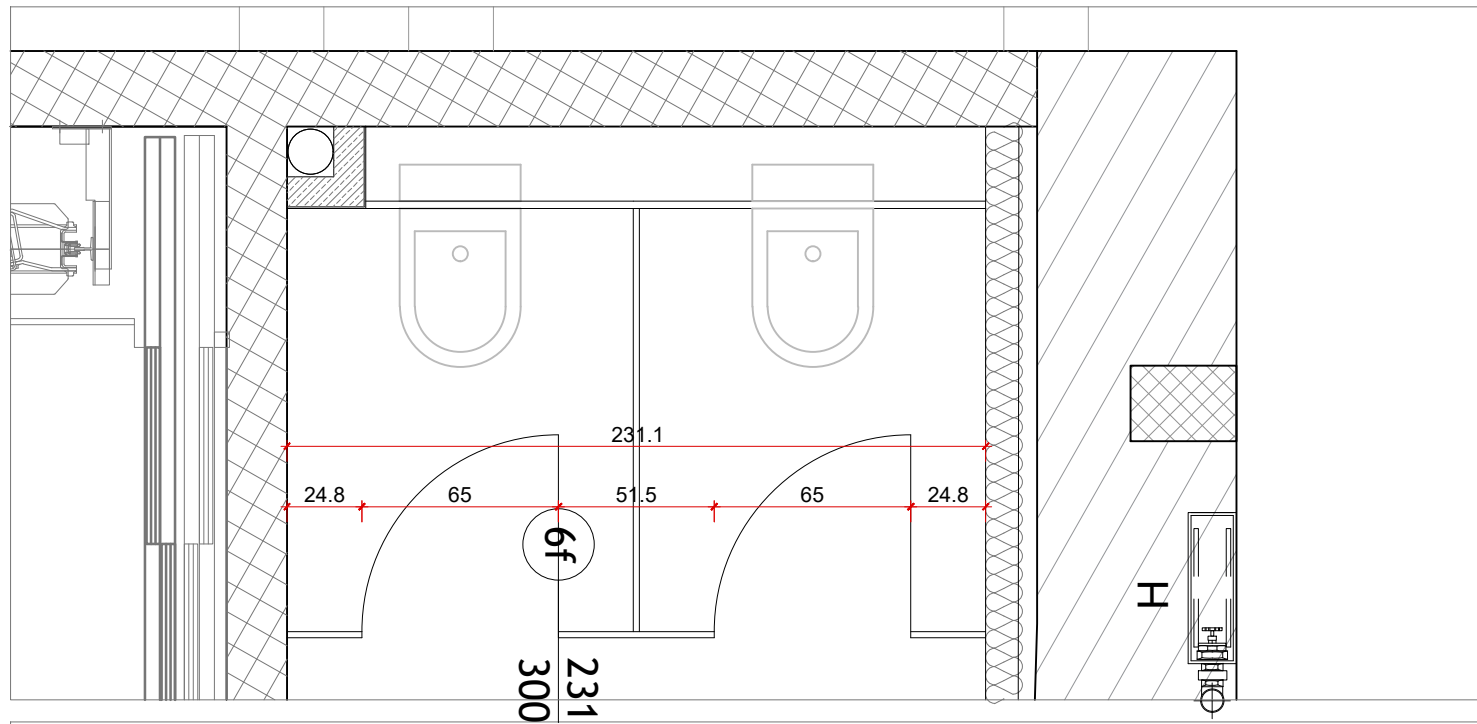

**UNUTARNJA STOLARIJA** **ST. 5f**

PREGRADE WC-A OD VODOOTPORNH VISOKOTLAČNO PREŠANIH LAMINAT PLOČA (HPL) S DVA DVOKRILNA ZAOKRETNNA VRATA DIM. 65/210 cm. MONTIRAJU SE DIJELOM NA POTKONSTRUKCIJU PRIČVRŠĆENU NA KNAUF ZID.

ukupna dimenzija: 231 x 340  
vrata: 2x 65x210

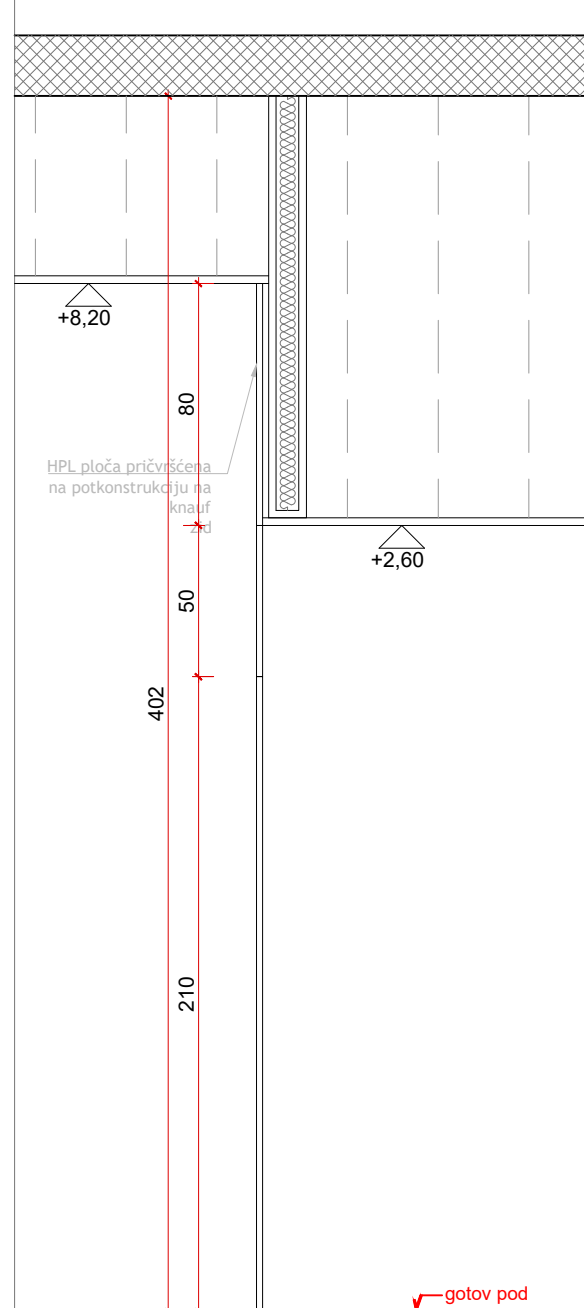

PRESJEK A-A

**PROARRH** Proarrh mateković d.o.o. Kneza Mislava 15, Zagreb, 10000, Croatia  
t. +385 1 46 36 015, +385 1 46 36 002, f. + 385 1 45 52 878

za arhitektonsko projektiranje

investitor:	Virovitičko-podravka županija, Trg Ljudevita Patačića 1, 33000 Virovitica OIB: 93362201007	glavni projektant:	<del>DESIMIR</del> Mateković, dipl.ing.arh.	sadržaj:	
građevina:	Centar za kulturu zdravlja - Rekonstrukcija dvorca Janković u Cabuni	projektant:	<b>BRVARRJE</b> Davor Mateković, dipl.ing.arh.	br. t.d.	07/14
lokacija:	k.č.br. 607/2 k.o. Cabuna	suradnici:	Tomislav Stojan, dipl.ing.arh., Nataša Mandir, mag.ing.arch.,	datum:	studenj 2020.
faza:	<b>IZVEDBENI PROJEKT</b>	direktor:	Tomislav Stojan, dipl.ing.arh.	list:	

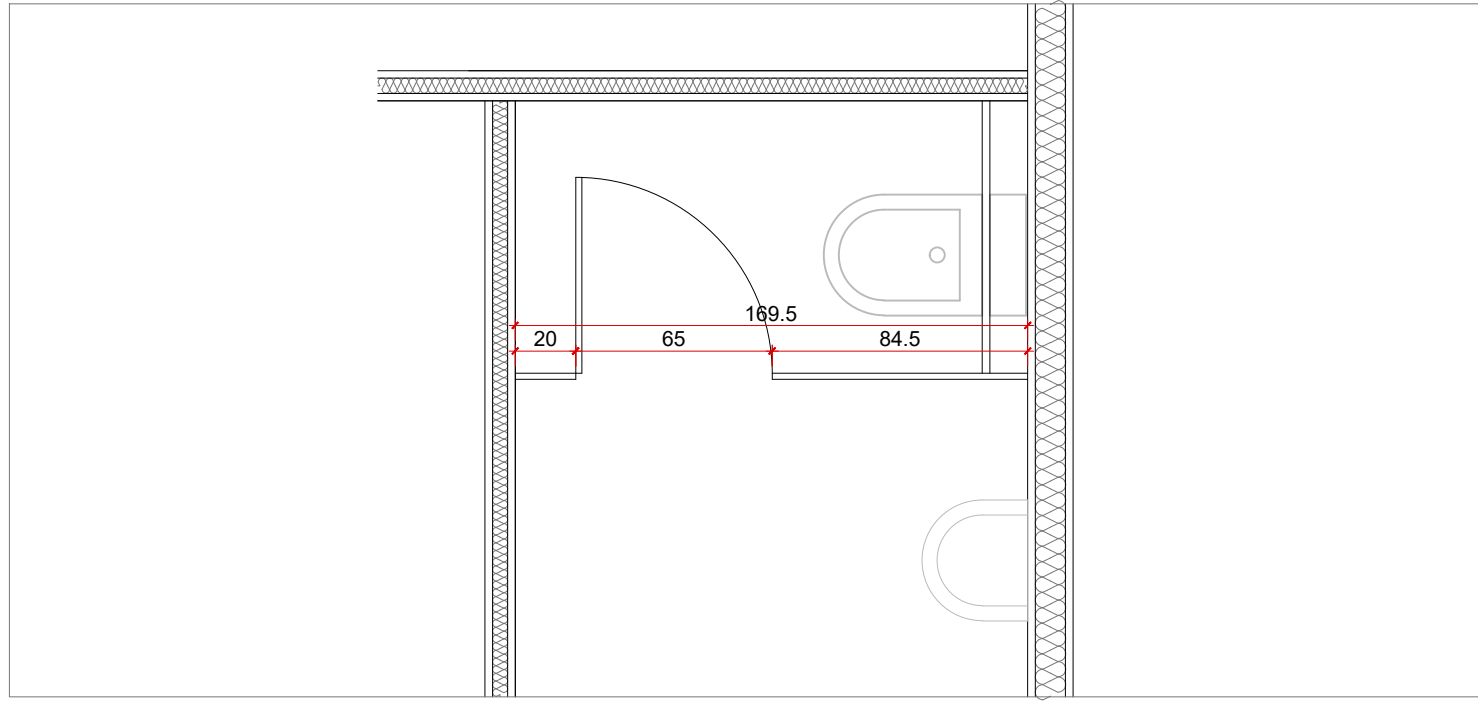

**UNUTARNJA STOLARIJA** **ST. 5g**

PREGRADE WC-A OD VODOOTPORNIH VISOKOTLAČNO PREŠANIH LAMINAT PLOČA (HPL) JEDNOKRILNIM ZAOKRETNIM VRATIMA DIM. 65/200 cm. MONTIRAJU SE NA ALU NOSAČE ODIGNUTE OD PODA 15 cm.

ukupna dimenzija : 170x340  
vrata 65x210

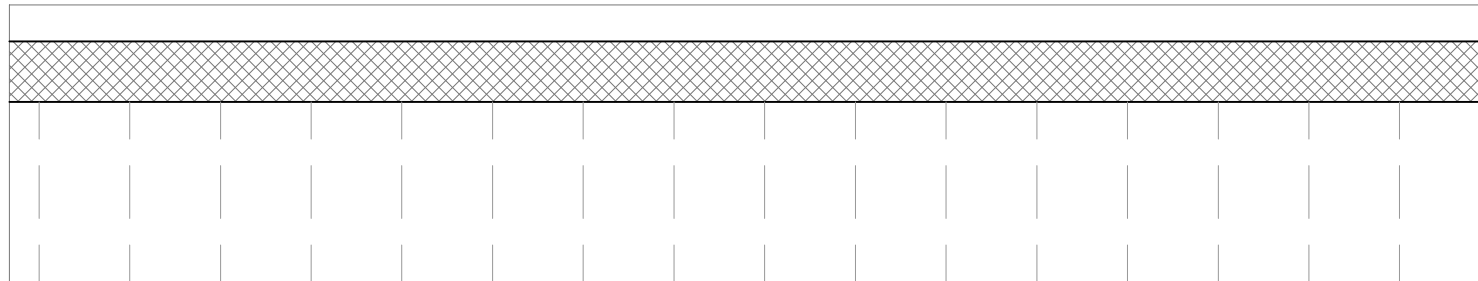

POGLED

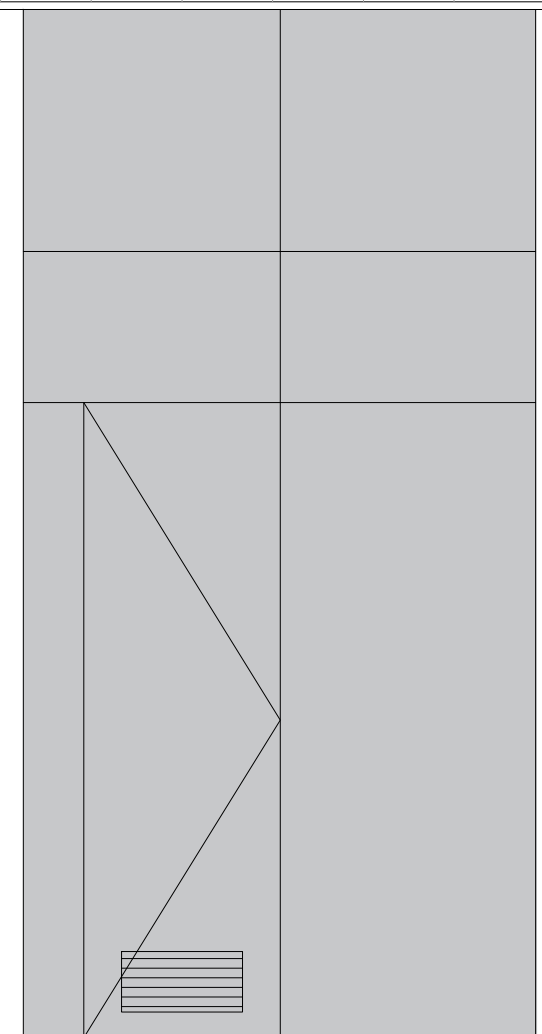

gotov pod

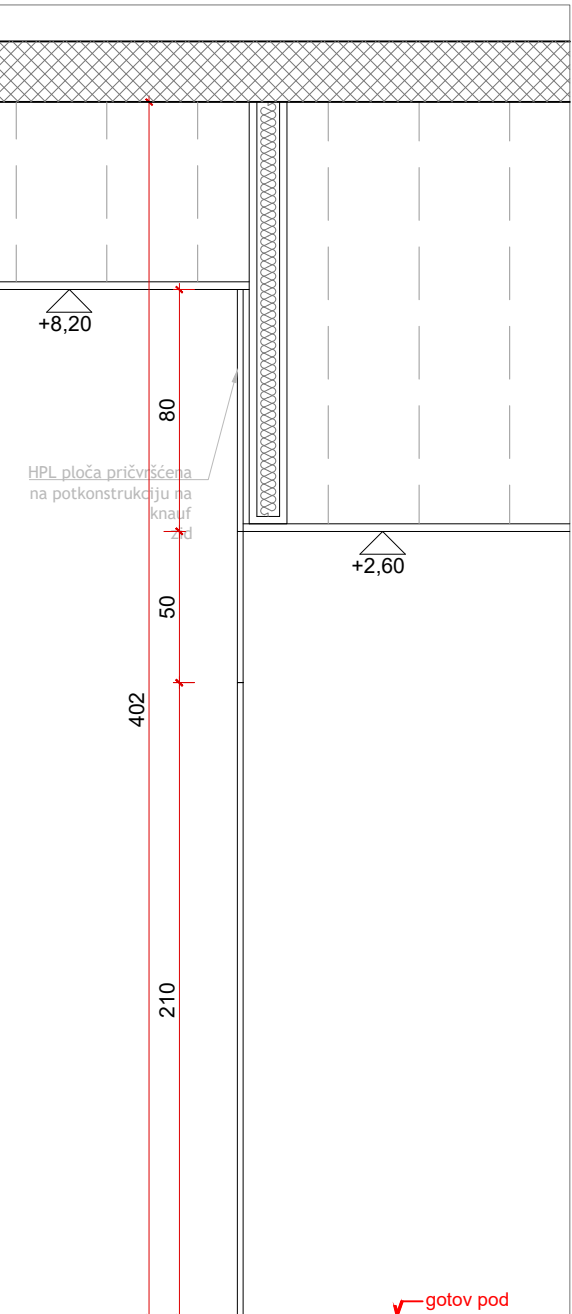

PRESJEK A-A

gotov pod

**PROARRH** Proarrh mateković d.o.o. Kneza Mislava 15, Zagreb, 10000, Croatia  
t. +385 1 46 36 015, +385 1 46 36 002, f. + 385 1 45 52 878  
za arhitektonsko projektiranje

investitor:	Virovitičko-podravska županija, Trg Ljudevita Patačića 1, 33000 Virovitica OIB: 9336201007	glavni projektant:	Dobroslav Mateković, dipl.ing.arh.	sadržaj:	
građevina:	Centar za kulturu zdravlja - Rekonstrukcija dvorca Janjčević u Cabuni	projektant:	BRVARRH Davor Mateković, dipl.ing.arh.	br. t.d.	07/14
lokacija:	k.č.br. 607/2 k.o. Cabuna	suradnici:	Tomislav Stojan, dipl.ing.arh., Nataša Mandir, mag.ing.arch.	datum:	studen 2020.
faza:	IZVEDBENI PROJEKT	direktor:	Tomislav Stojan, dipl.ing.arh.	list:	

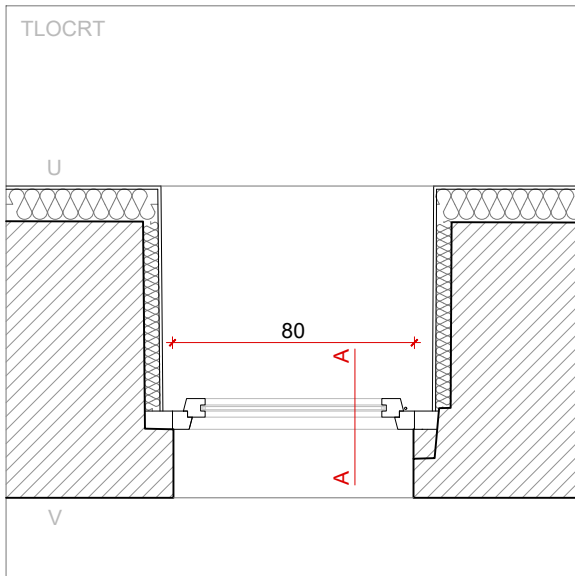

VANJSKA  
STOLARIJA

ST. 07

JEDNOKRILNI ZAOKRETNO-OTKLOPNI PROZOR  
UGRADBA U POSTOJEĆI ZID OD OPEKE

80/70 cm

kom: 14

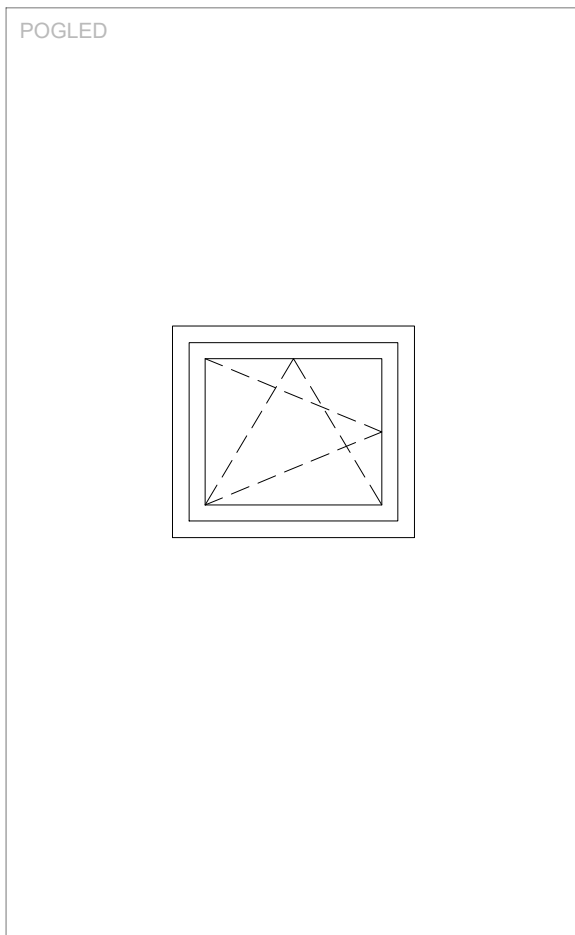

PRESJEK A-A

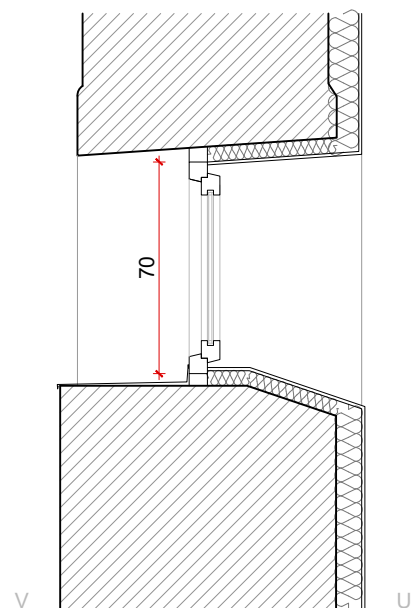

PROARH

Proarh mateković d.o.o.  
za arhitektonsko projektiranje

Kneza Mislava 15, Zagreb, 10000, Croatia  
t. +385 1 46 36 015, +385 1 46 36 002, f. + 385 1 45 52 878

investitor: Virovitičko-podravska županija, Trg Ljudevita Patačića 1, 33000 Virovitica OIB: 93362201007	glavni projektant: Davor Mateković, dipl.ing.arh.	sadržaj: <b>SHEME STOLARIJE</b> m 1:25
	projektant: Davor Mateković, dipl.ing.arh.	
građevina: Centar za kulturu zdravlja - Rekonstrukcija dvorca Janković u Cabuni	suradnici: Tomislav Stojan, dipl.ing.arh., Nataša Mandir, mag.ing.arch.,	br. t.d. 07/14
		datum: studeni 2020.
lokacija: k.č.br. 607/2 k.o. Cabuna	direktor: Tomislav Stojan, dipl.ing.arh.	list:
faza: <b>IZVEDBENI PROJEKT</b>		

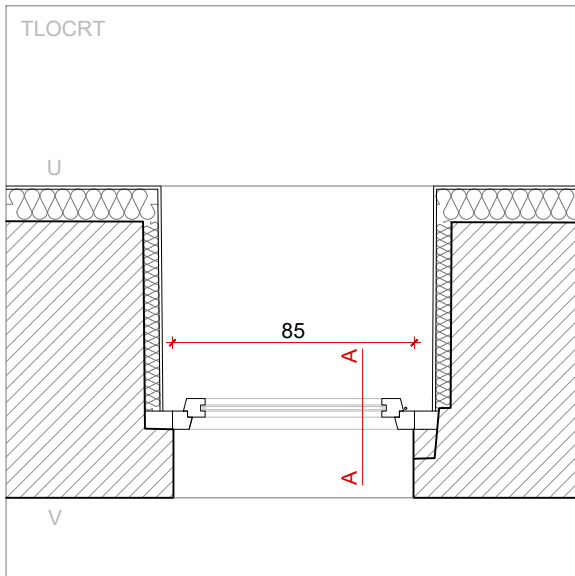

VANJSKA  
STOLARIJA

ST. 08

JEDNOKRILNI ZAOKRETNO-OTKLOPNI PROZOR  
UGRADBA U POSTOJEĆI ZID OD OPEKE

85/70 cm

kom: 8

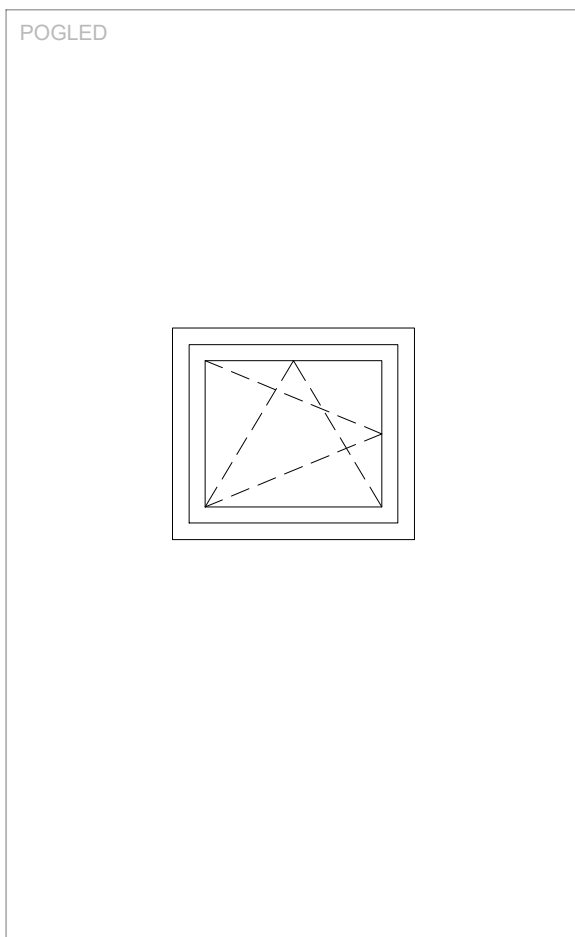

PRESJEK A-A

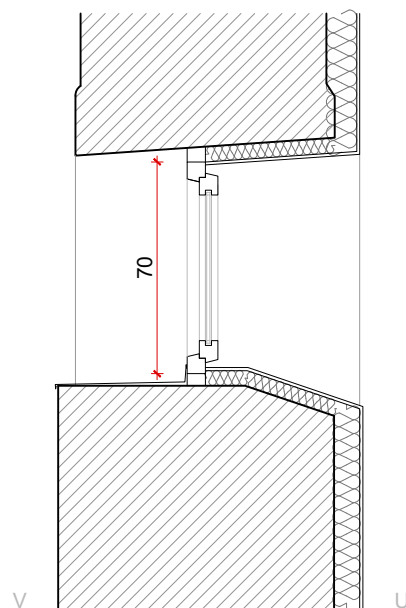

PROARH

Proarh mateković d.o.o.  
za arhitektonsko projektiranje

Kneza Mislava 15, Zagreb, 10000, Croatia  
t. +385 1 46 36 015, +385 1 46 36 002, f. + 385 1 45 52 878

investitor: Virovitičko-podravaska županija, Trg Ljudevita Patačića 1, 33000 Virovitica OIB: 93362201007	glavni projektant: Davor Mateković, dipl.ing.arh.	sadržaj: <b>SHEME STOLARIJE</b> m 1:25
	projektant: Davor Mateković, dipl.ing.arh.	
građevina: Centar za kulturu zdravlja - Rekonstrukcija dvorca Janković u Cabuni	suradnici: Tomislav Stojan, dipl.ing.arh., Nataša Mandir, mag.ing.arch.,	br. t.d. 07/14
		datum: studeni 2020.
lokacija: k.č.br. 607/2 k.o. Cabuna	direktor: Tomislav Stojan, dipl.ing.arh.	list:
faza: <b>IZVEDBENI PROJEKT</b>		



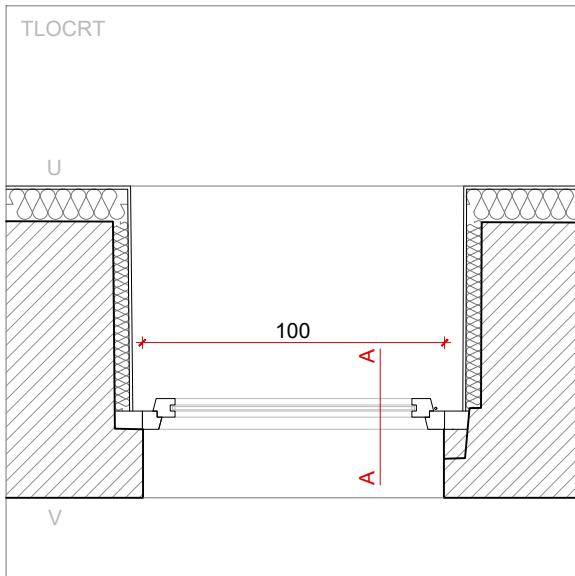

VANJSKA  
STOLARIJA

ST. 09

JEDNOKRILNI ZAOKRETNO-OTKLOPNI PROZOR  
UGRADBA U POSTOJEĆI ZID OD OPEKE

100/70 cm

kom: 4

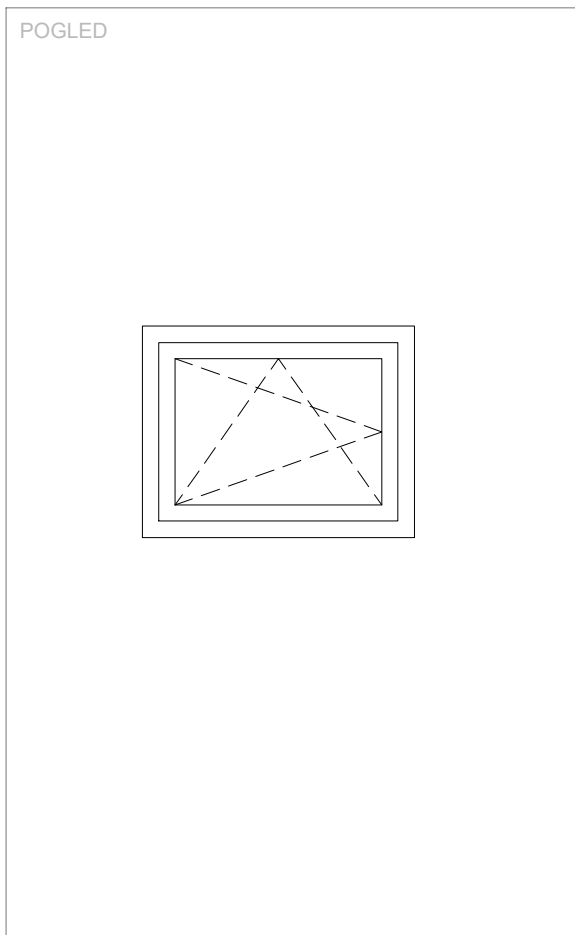

PRESJEK A-A

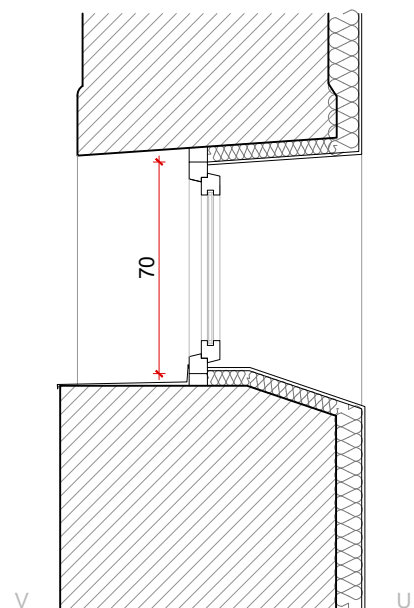

PROARH

Proarh mateković d.o.o.  
za arhitektonsko projektiranje

Kneza Mislava 15, Zagreb, 10000, Croatia  
t. +385 1 46 36 015, +385 1 46 36 002, f. + 385 1 45 52 878

investitor: Virovitičko-podravka županija, Trg Ljudevita Patačića 1, 33000 Virovitica OIB: 93362201007	glavni projektant: Davor Mateković, dipl.ing.arh.	sadržaj: <b>SHEME STOLARIJE</b> m 1:25
	projektant: Davor Mateković, dipl.ing.arh.	
građevina: Centar za kulturu zdravlja - Rekonstrukcija dvorca Janković u Cabuni	suradnici: Tomislav Stojan, dipl.ing.arh., Nataša Mandir, mag.ing.arch.,	br. t.d. 07/14
lokacija: k.č.br. 607/2 k.o. Cabuna		datum: studeni 2020.
faza: <b>IZVEDBENI PROJEKT</b>	direktor: Tomislav Stojan, dipl.ing.arh.	list:

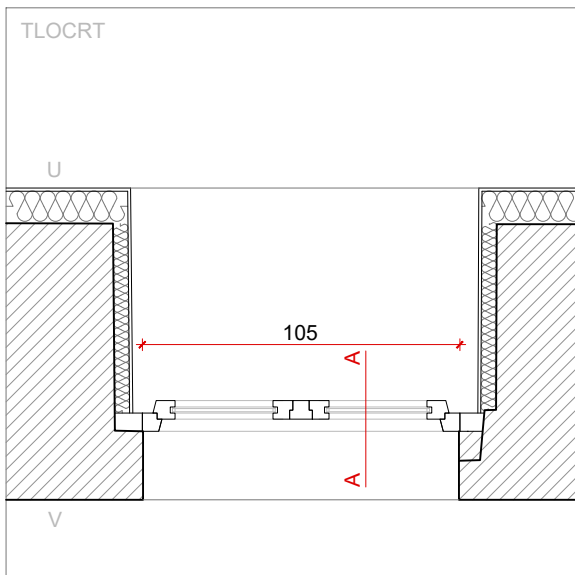

VANJSKA  
STOLARIJA

ST. 10

DVOKRILNI ZAOKRETNO-OTKLOPNI PROZOR  
UGRADBA U POSTOJEĆI ZID OD OPEKE

105/70 cm

kom: 1

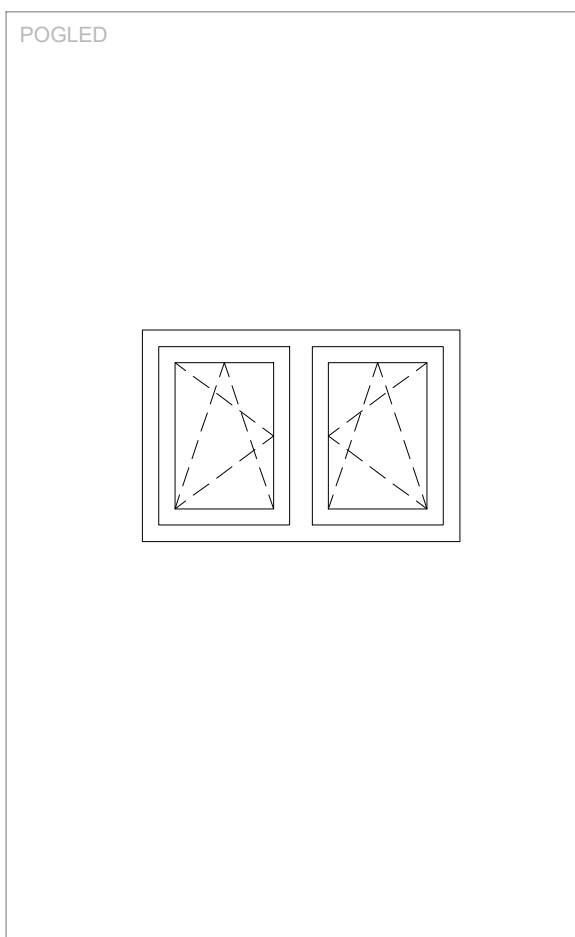

PRESJEK A-A

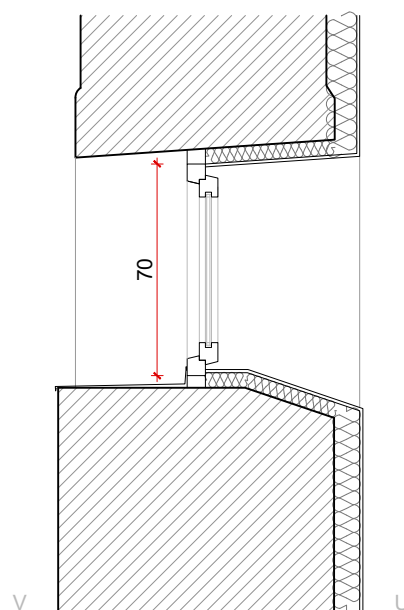

PROARH

Proarh mateković d.o.o.  
za arhitektonsko projektiranje

Kneza Mislava 15, Zagreb, 10000, Croatia  
t. +385 1 46 36 015, +385 1 46 36 002, f. + 385 1 45 52 878

investitor: Virovitičko-podravaska županija, Trg Ljudevita Patačića 1, 33000 Virovitica OIB: 93362201007	glavni projektant: Davor Mateković, dipl.ing.arh.	sadržaj: <b>SHEME STOLARIJE</b> m 1:25
	projektant: Davor Mateković, dipl.ing.arh.	
građevina: Centar za kulturu zdravlja - Rekonstrukcija dvorca Janković u Cabuni	suradnici: Tomislav Stojan, dipl.ing.arh., Nataša Mandir, mag.ing.arch.,	br. t.d. 07/14
		datum: studeni 2020.
lokacija: k.č.br. 607/2 k.o. Cabuna	direktor: Tomislav Stojan, dipl.ing.arh.	list:
faza: <b>IZVEDBENI PROJEKT</b>		

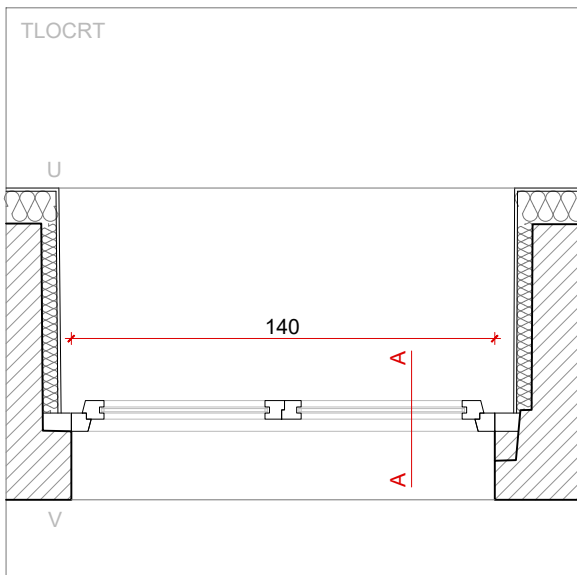

VANJSKA  
STOLARIJA

ST. 11

DVOKRILNI ZAOKRETNO-OTKLOPNI PROZOR  
UGRADBA U POSTOJEĆI ZID OD OPEKE

140/70 cm

kom: 3

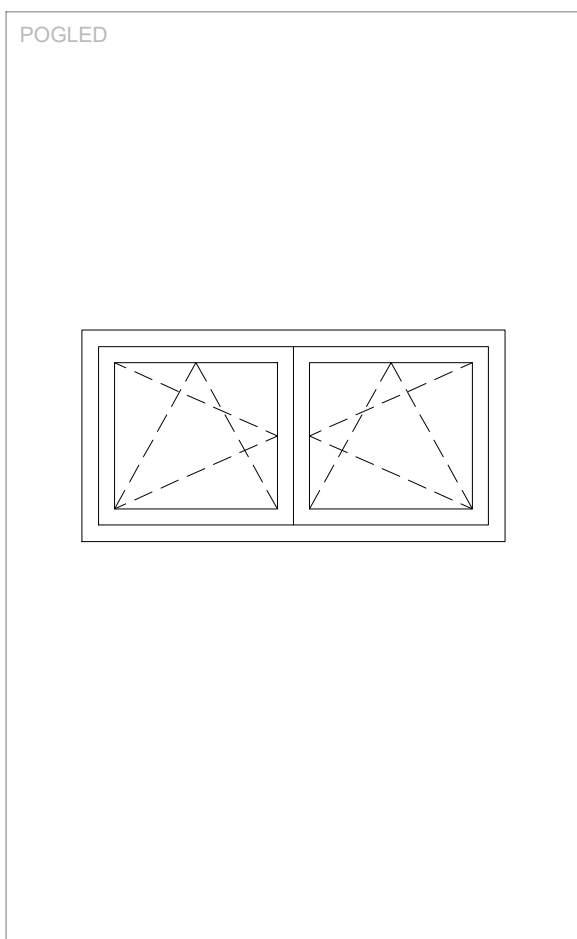

PRESJEK A-A

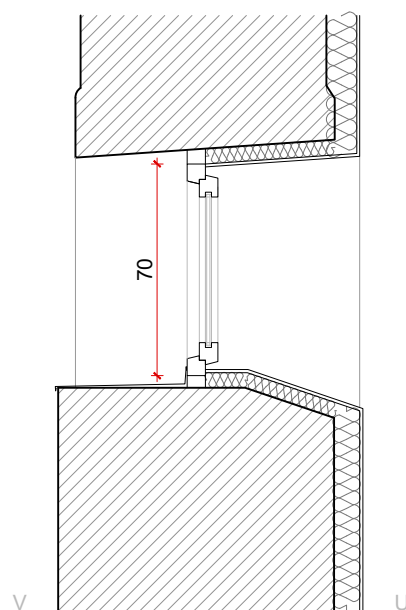

PROARH

Proarh mateković d.o.o.  
za arhitektonsko projektiranje

Kneza Mislava 15, Zagreb, 10000, Croatia  
t. +385 1 46 36 015, +385 1 46 36 002, f. + 385 1 45 52 878

investitor: Virovitičko-podravska županija, Trg Ljudevita Patačića 1, 33000 Virovitica OIB: 93362201007	glavni projektant: Davor Mateković, dipl.ing.arh.	sadržaj: <b>SHEME STOLARIJE</b> m 1:25
	projektant: Davor Mateković, dipl.ing.arh.	
građevina: Centar za kulturu zdravlja - Rekonstrukcija dvorca Janković u Cabuni	suradnici: Tomislav Stojan, dipl.ing.arh., Nataša Mandir, mag.ing.arch.,	br. t.d. 07/14
lokacija: k.č.br. 607/2 k.o. Cabuna		datum: studeni 2020.
faza: <b>IZVEDBENI PROJEKT</b>	direktor: Tomislav Stojan, dipl.ing.arh.	list:

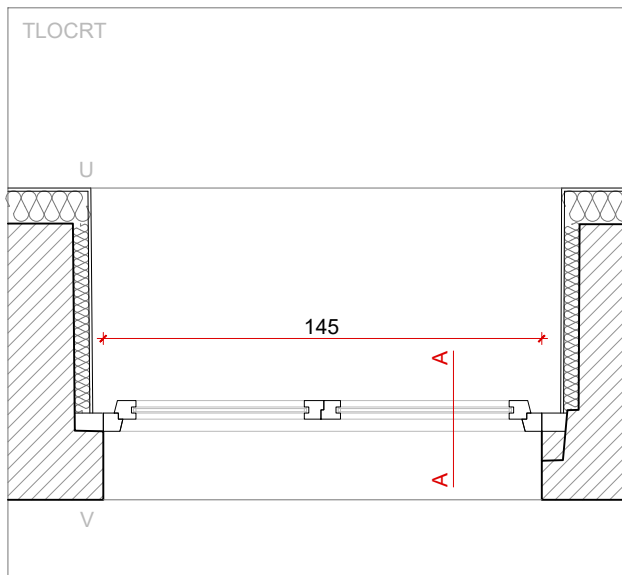

VANJSKA  
STOLARIJA

ST. 12

DVOKRILNI ZAOKRETNO-OTKLOPNI PROZOR  
UGRADBA U POSTOJEĆI ZID OD OPEKE

145/70 cm

kom: 3

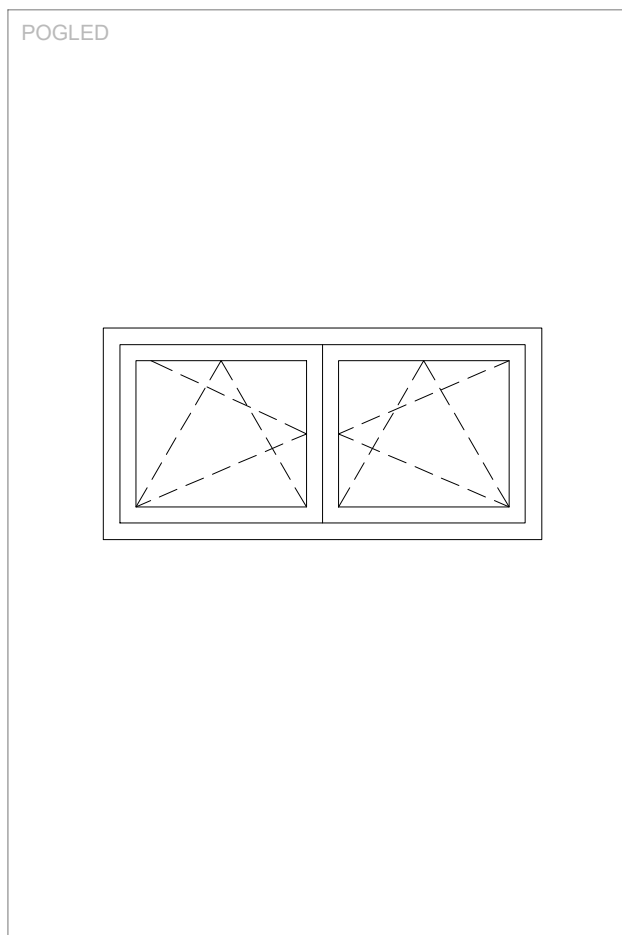

PRESJEK A-A

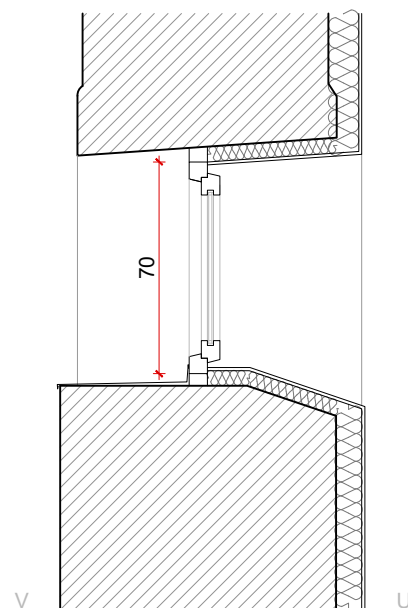

PROARH

Proarh mateković d.o.o.  
za arhitektonsko projektiranje

Kneza Mislava 15, Zagreb, 10000, Croatia  
t. +385 1 46 36 015, +385 1 46 36 002, f. + 385 1 45 52 878

investitor: Virovitičko-podravska županija, Trg Ljudevita Patačića 1, 33000 Virovitica OIB: 93362201007	glavni projektant: Davor Mateković, dipl.ing.arh.	sadržaj: <b>SHEME STOLARIJE</b> m 1:25
	projektant: Davor Mateković, dipl.ing.arh.	
građevina: Centar za kulturu zdravlja - Rekonstrukcija dvorca Janković u Cabuni	suradnici: Tomislav Stojan, dipl.ing.arh., Nataša Mandir, mag.ing.arch.,	br. t.d. 07/14
lokacija: k.č.br. 607/2 k.o. Cabuna		datum: studeni 2020.
faza: <b>IZVEDBENI PROJEKT</b>	direktor: Tomislav Stojan, dipl.ing.arh.	list:

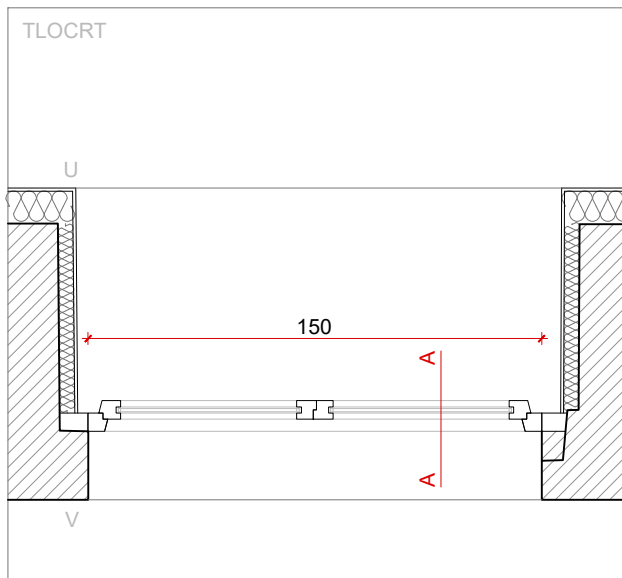

VANJSKA  
STOLARIJA

ST. 13

DVOKRILNI ZAOKRETNO-OTKLOPNI PROZOR  
UGRADBA U POSTOJEĆI ZID OD OPEKE

150/70 cm

kom: 2

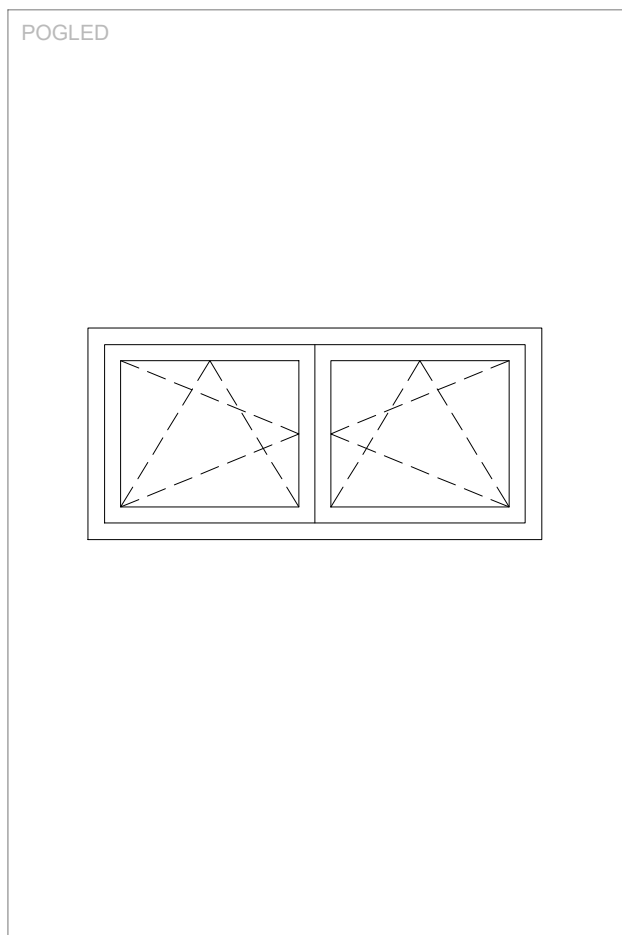

PRESJEK A-A

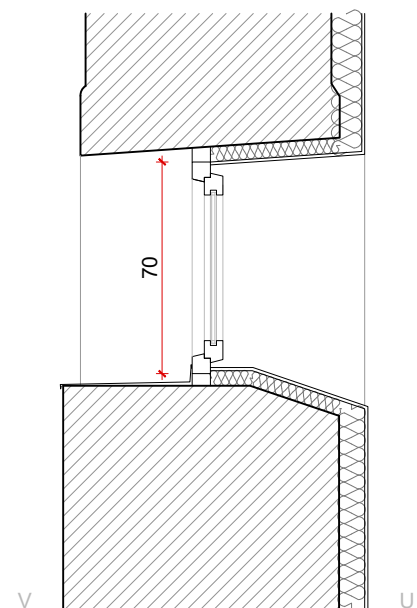

PROARH

Proarh mateković d.o.o.  
za arhitektonsko projektiranje

Kneza Mislava 15, Zagreb, 10000, Croatia  
t. +385 1 46 36 015, +385 1 46 36 002, f. + 385 1 45 52 878

investitor: Virovitičko-podravška županija, Trg Ljudevita Patačića 1, 33000 Virovitica OIB: 93362201007	glavni projektant: Davor Mateković, dipl.ing.arh.	sadržaj: <b>SHEME STOLARIJE</b> m 1:25
	projektant: Davor Mateković, dipl.ing.arh.	
građevina: Centar za kulturu zdravlja - Rekonstrukcija dvorca Janković u Cabuni	suradnici: Tomislav Stojan, dipl.ing.arh., Nataša Mandir, mag.ing.arch.,	br. t.d. 07/14
lokacija: k.č.br. 607/2 k.o. Cabuna		datum: studeni 2020.
faza: <b>IZVEDBENI PROJEKT</b>	direktor: Tomislav Stojan, dipl.ing.arh.	list:

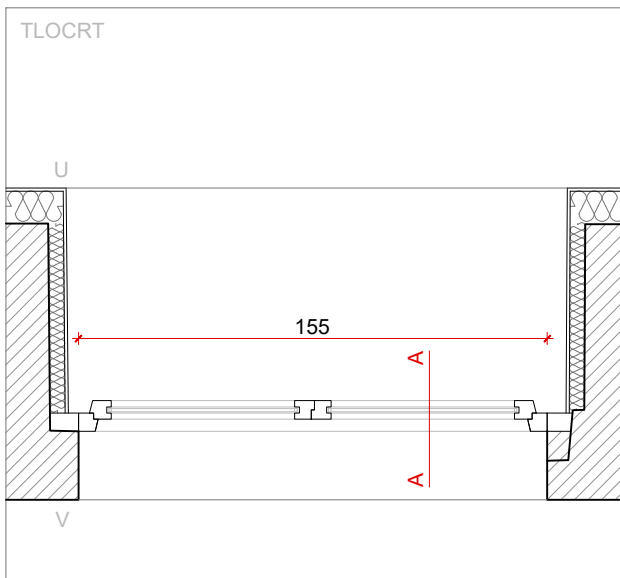

VANJSKA  
STOLARIJA

ST. 14

DVOKRILNI ZAOKRETNO-OTKLOPNI PROZOR  
UGRADBA U POSTOJEĆI ZID OD OPEKE

155/70 cm

kom: 1

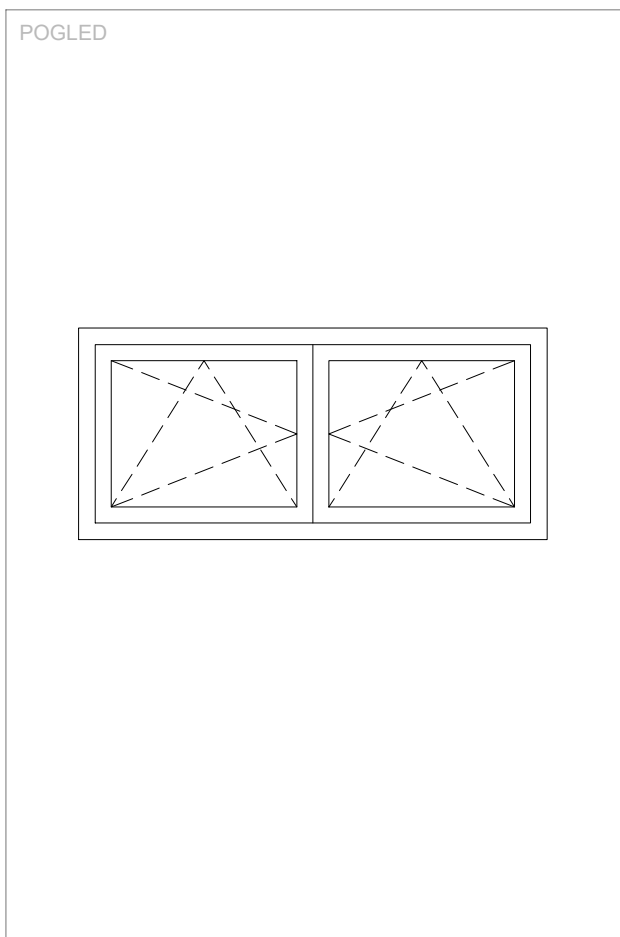

PRESJEK A-A

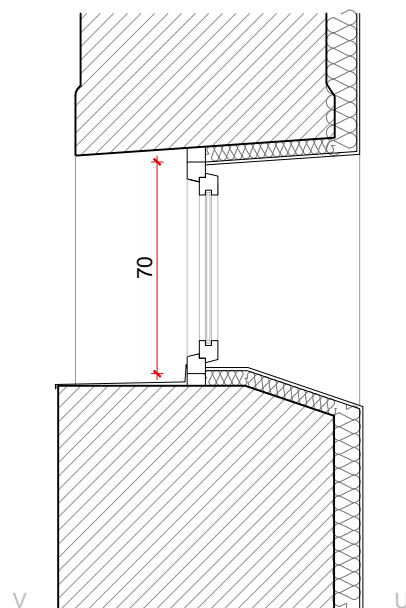

PROARH

Proarh mateković d.o.o.  
za arhitektonsko projektiranje

Kneza Mislava 15, Zagreb, 10000, Croatia  
t. +385 1 46 36 015, +385 1 46 36 002, f. + 385 1 45 52 878

investitor: Virovitičko-podravaska županija, Trg Ljudevita Patačića 1, 33000 Virovitica OIB: 93362201007	glavni projektant: Davor Mateković, dipl.ing.arh.	sadržaj: <b>SHEME STOLARIJE</b> m 1:25
	projektant: Davor Mateković, dipl.ing.arh.	
građevina: Centar za kulturu zdravlja - Rekonstrukcija dvorca Janković u Cabuni	suradnici: Tomislav Stojan, dipl.ing.arh., Nataša Mandir, mag.ing.arch.,	br. t.d. 07/14
lokacija: k.č.br. 607/2 k.o. Cabuna		datum: studeni 2020.
faza: <b>IZVEDBENI PROJEKT</b>	direktor: Tomislav Stojan, dipl.ing.arh.	list:

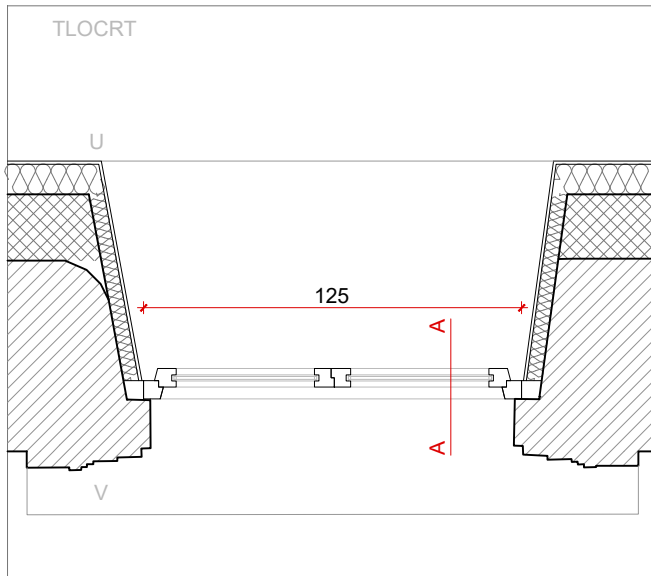

VANJSKA  
STOLARIJA

ST. 15

DVOKRILNI ZAOKRETNO-OTKLOPNI PROZOR S  
ZAOKRETNO-OTKLOPNIM NADSVJETLOM  
UGRADBA U POSTOJEĆI ZID OD OPEKE

125/210 cm

kom: 9

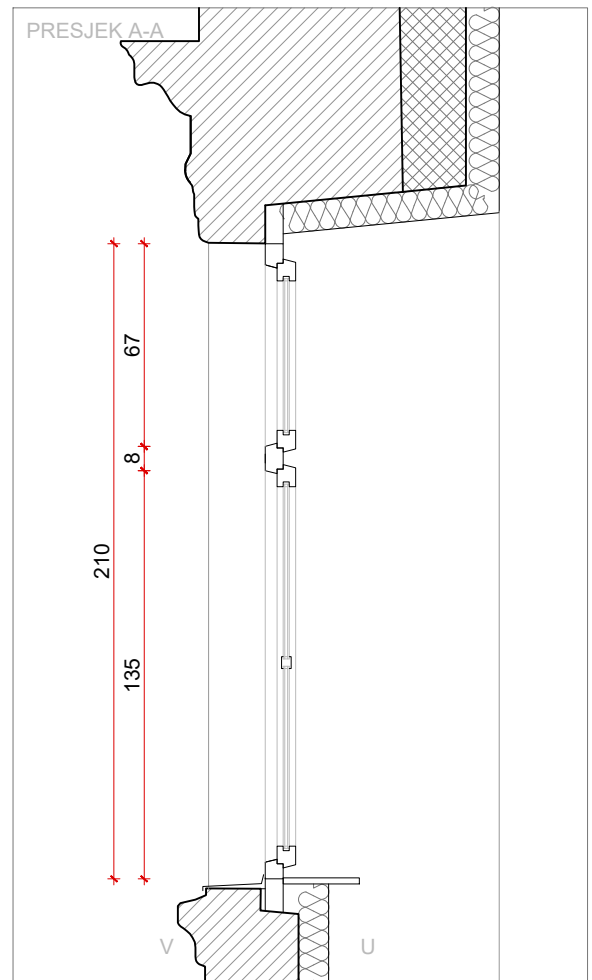
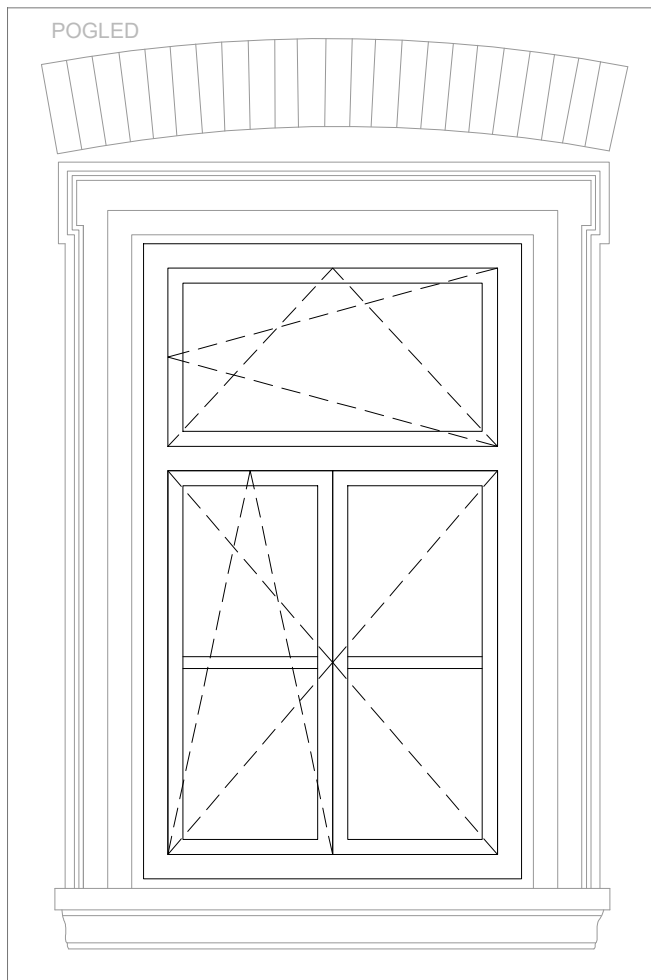

**P R O A R H**

Proarh mateković d.o.o.  
za arhitektonsko projektiranje

Kneza Mislava 15, Zagreb, 10000, Croatia  
t. +385 1 46 36 015, +385 1 46 36 002, f. + 385 1 45 52 878

investitor:	Virovitičko-podravka županija, Trg Ljudevita Patačića 1, 33000 Virovitica OIB: 93362201007	glavni projektant:	Davor Mateković, dipl.ing.arh.	sadržaj:	<b>SHEME STOLARIJE</b> m 1:25
građevina:	Centar za kulturu zdravlja - Rekonstrukcija dvorca Janković u Cabuni	projektant:	Davor Mateković, dipl.ing.arh.	br. t.d.	07/14
lokacija:	k.č.br. 607/2 k.o. Cabuna	suradnici:	Tomislav Stojan, dipl.ing.arh., Nataša Mandir, mag.ing.arch.,	datum:	studeni 2020.
faza:	<b>IZVEDBENI PROJEKT</b>	direktor:	Tomislav Stojan, dipl.ing.arh.	list:	

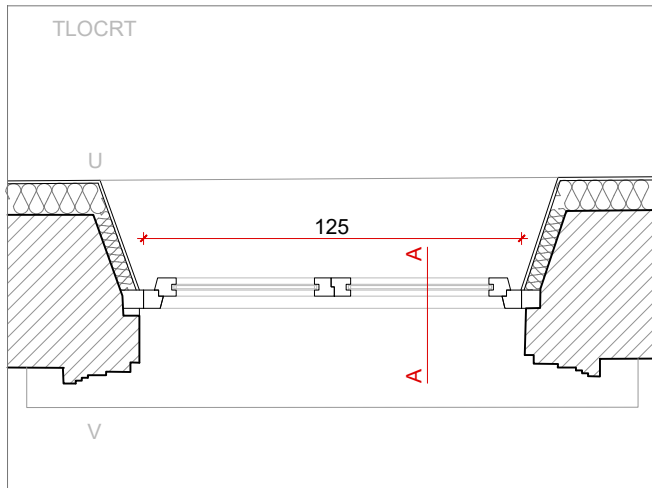

VANJSKA  
STOLARIJA

ST. 16

DVOKRILNI ZAOKRETNO-OTKLOPNI PROZOR S  
ZAOKRETNO-OTKLOPNIM NADSVJETLOM  
UGRADBA U POSTOJEĆI ZID OD OPEKE

125/230 cm

kom: 24

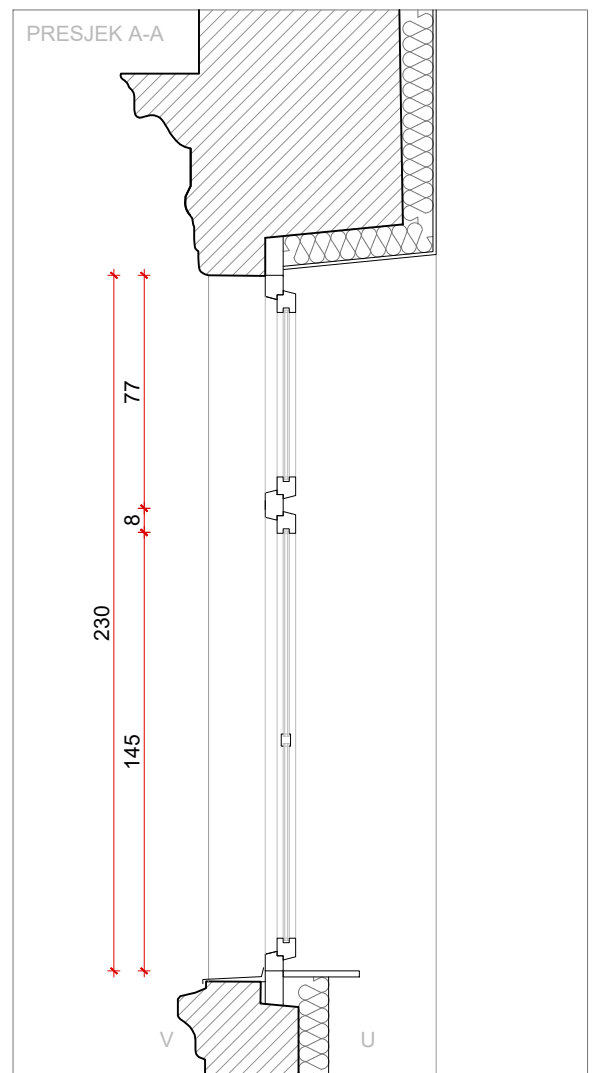
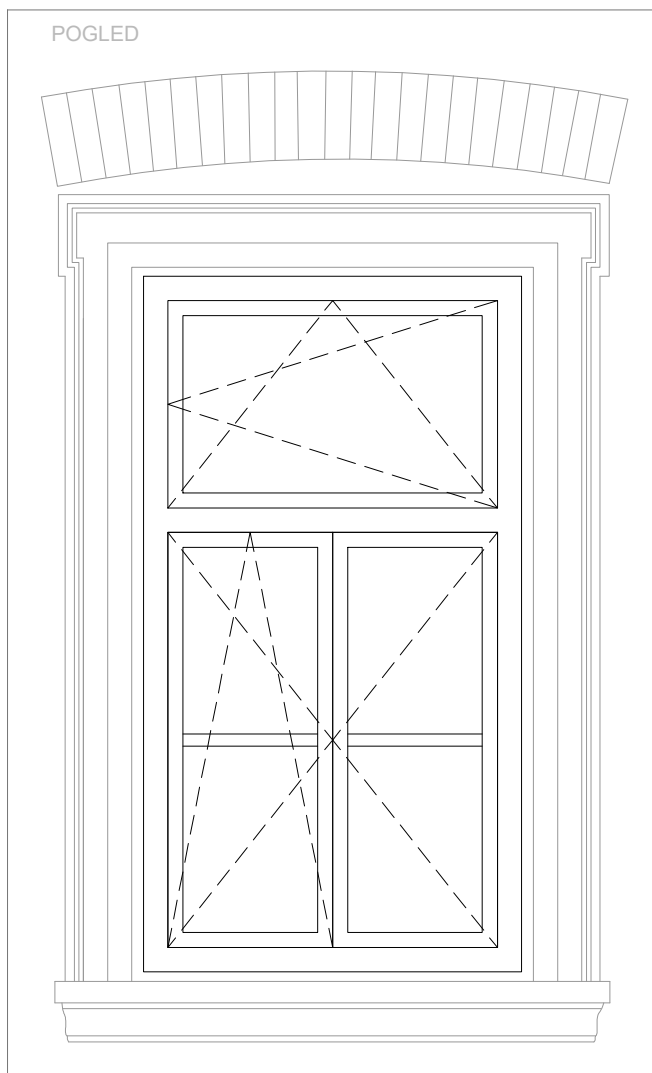

**PROARH**

Proarh mateković d.o.o.  
za arhitektonsko projektiranje

Kneza Mislava 15, Zagreb, 10000, Croatia  
t. +385 1 46 36 015, +385 1 46 36 002, f. + 385 1 45 52 878

investitor:	Virovitičko-podravska županija, Trg Ljudevita Patačića 1, 33000 Virovitica OIB: 93362201007	glavni projektant:	Davor Mateković, dipl.ing.arh.	sadržaj: <b>SHEME STOLARIJE</b> m 1:25
		projektant:	Davor Mateković, dipl.ing.arh.	
građevina:	Centar za kulturu zdravlja - Rekonstrukcija dvorca Janković u Cabuni	suradnici:	Tomislav Stojan, dipl.ing.arh., Nataša Mandir, mag.ing.arch.,	br. t.d. 07/14
lokacija:	k.č.br. 607/2 k.o. Cabuna			datum: studeni 2020.
faza:	<b>IZVEDBENI PROJEKT</b>	direktor:	Tomislav Stojan, dipl.ing.arh.	list:



TLOCRT

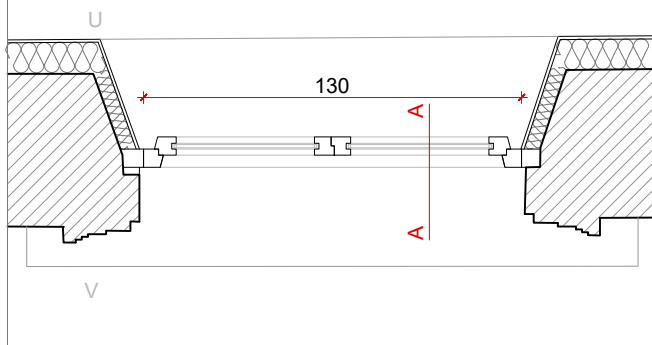

VANJSKA  
STOLARIJA

ST. 17

DVOKRILNI ZAOKRETNO-OTKLOPNI PROZOR S  
ZAOKRETNO-OTKLOPNIM NADSVJETLOM  
UGRADBA U POSTOJEĆI ZID OD OPEKE

130/230 cm

kom: 6

POGLED

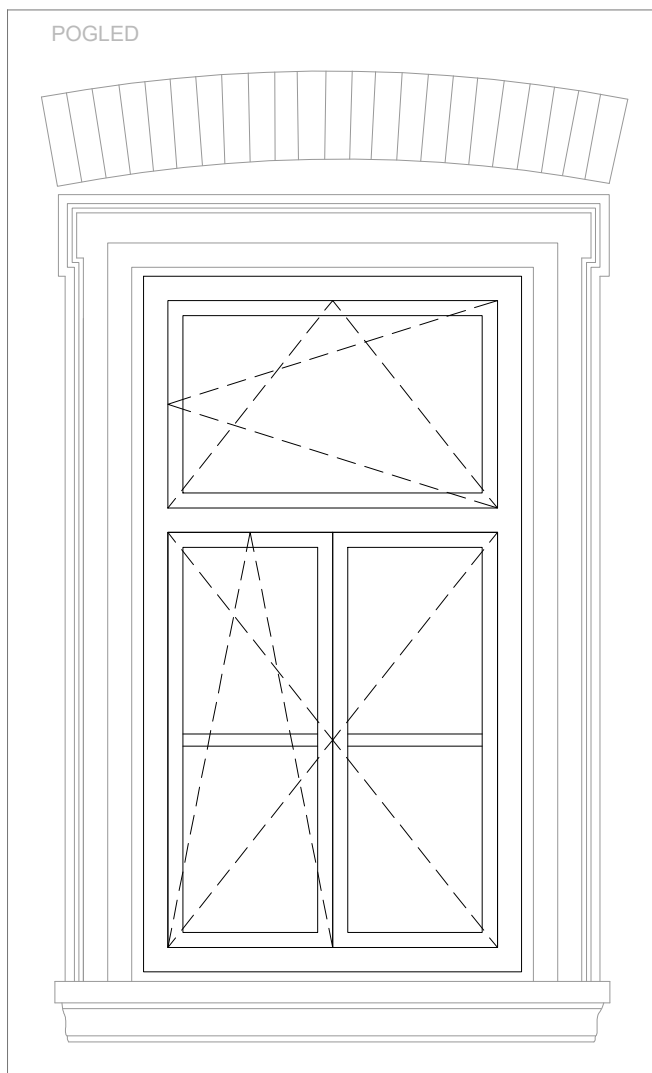

PRESJEK A-A

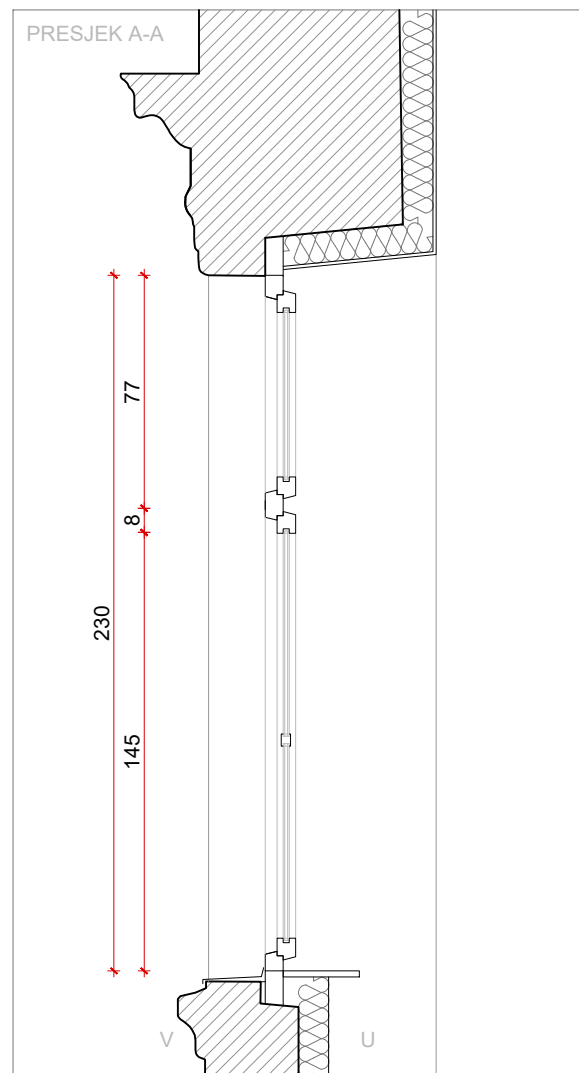

PROARH

Proarh mateković d.o.o.  
za arhitektonsko projektiranje

Kneza Mislava 15, Zagreb, 10000, Croatia  
t. +385 1 46 36 015, +385 1 46 36 002, f. + 385 1 45 52 878

investitor:	Virovitičko-podravska županija, Trg Ljudevita Patačića 1, 33000 Virovitica OIB: 93362201007	glavni projektant:	Davor Mateković, dipl.ing.arh.	sadržaj:	SHEME STOLARIJE m 1:25
građevina:	Centar za kulturu zdravlja - Rekonstrukcija dvorca Janković u Cabuni	projektant:	Davor Mateković, dipl.ing.arh.	br. t.d.	07/14
lokacija:	k.č.br. 607/2 k.o. Cabuna	suradnici:	Tomislav Stojan, dipl.ing.arh., Nataša Mandir, mag.ing.arch.,	datum:	studeni 2020.
faza:	IZVEDBENI PROJEKT	direktor:	Tomislav Stojan, dipl.ing.arh.	list:	

TLOCRT

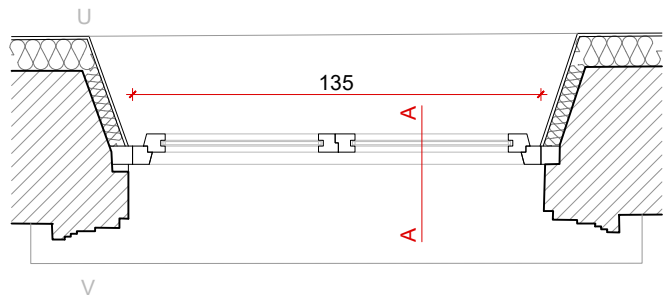

VANJSKA  
STOLARIJA

ST. 18

DVOKRILNI ZAOKRETNO-OTKLOPNI PROZOR SA  
ZAOKRETNO-OTKLOPNIM NADSVJETLOM  
UGRADBA U POSTOJEĆI ZID OD OPEKE

135/210 cm

kom: 11

POGLED

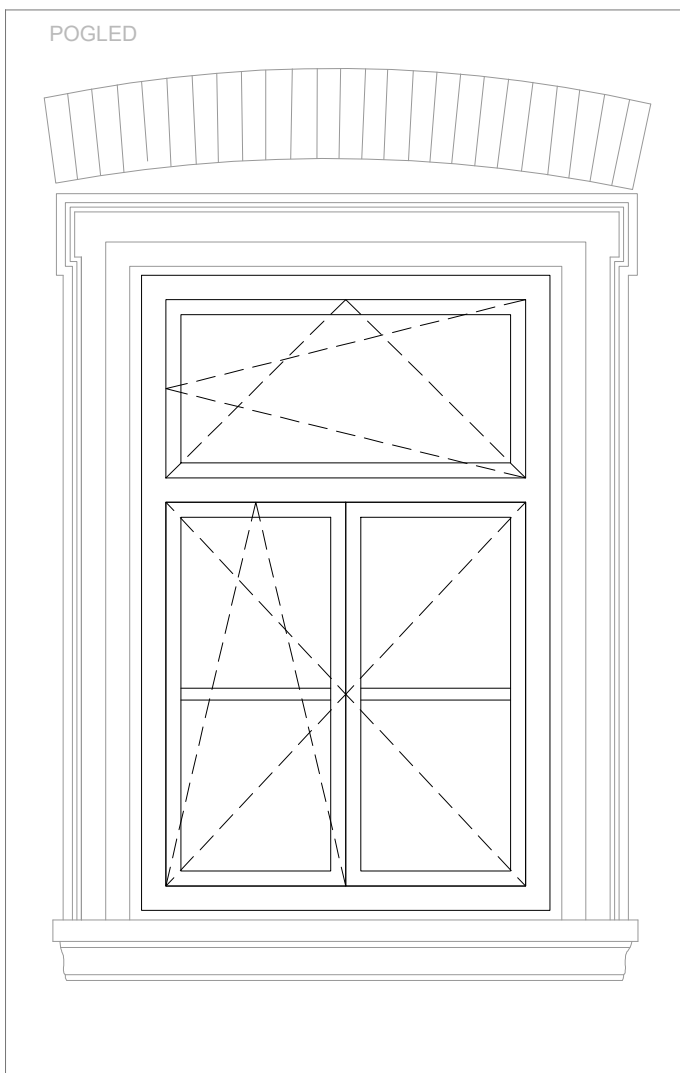

PRESJEK A-A

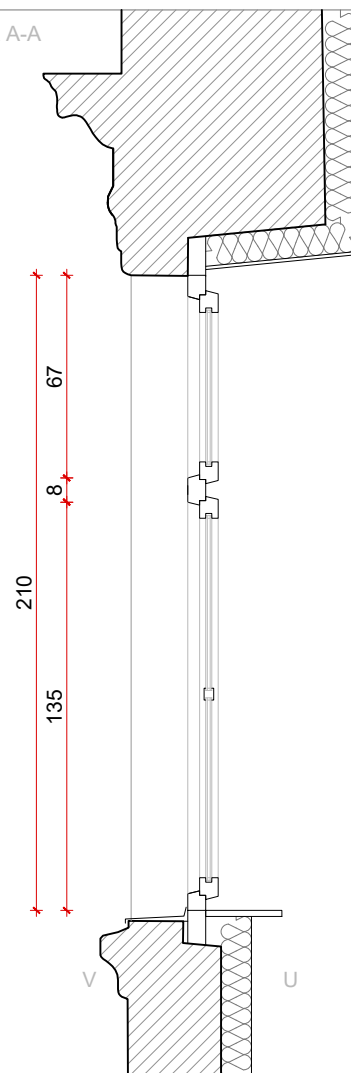

**P R O A R H**

Proarh mateković d.o.o.  
za arhitekonsko projektiranje

Kneza Mislava 15, Zagreb, 10000, Croatia  
t. +385 1 46 36 015, +385 1 46 36 002, f. + 385 1 45 52 878

investitor: Virovitičko-podravka županija, Trg Ljudevita Patačića 1, 33000 Virovitica OIB: 93362201007	glavni projektant: Davor Mateković, dipl.ing.arh.	sadržaj: <b>SHEME STOLARIJE</b> m 1:25
	projektant: Davor Mateković, dipl.ing.arh.	
građevina: Centar za kulturu zdravlja - Rekonstrukcija dvorca Janković u Cabuni	suradnici: Tomislav Stojan, dipl.ing.arh., Nataša Mandir, mag.ing.arch.,	br. t.d. 07/14
lokacija: k.č.br. 607/2 k.o. Cabuna		datum: studeni 2020.
faza: <b>IZVEDBENI PROJEKT</b>	direktor: Tomislav Stojan, dipl.ing.arh.	list:

TLOCRT

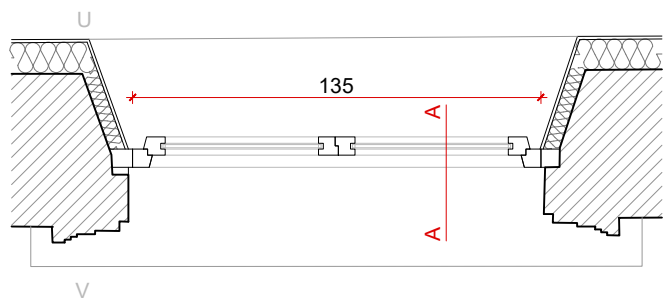

VANJSKA  
STOLARIJA

ST. 19

DVOKRILNI ZAOKRETNO-OTKLOPNI PROZOR S  
ZAOKRETNO-OTKLOPNIM NADSVJETLOM  
UGRADBA U POSTOJEĆI ZID OD OPEKE

135/230 cm

kom: 1

POGLED

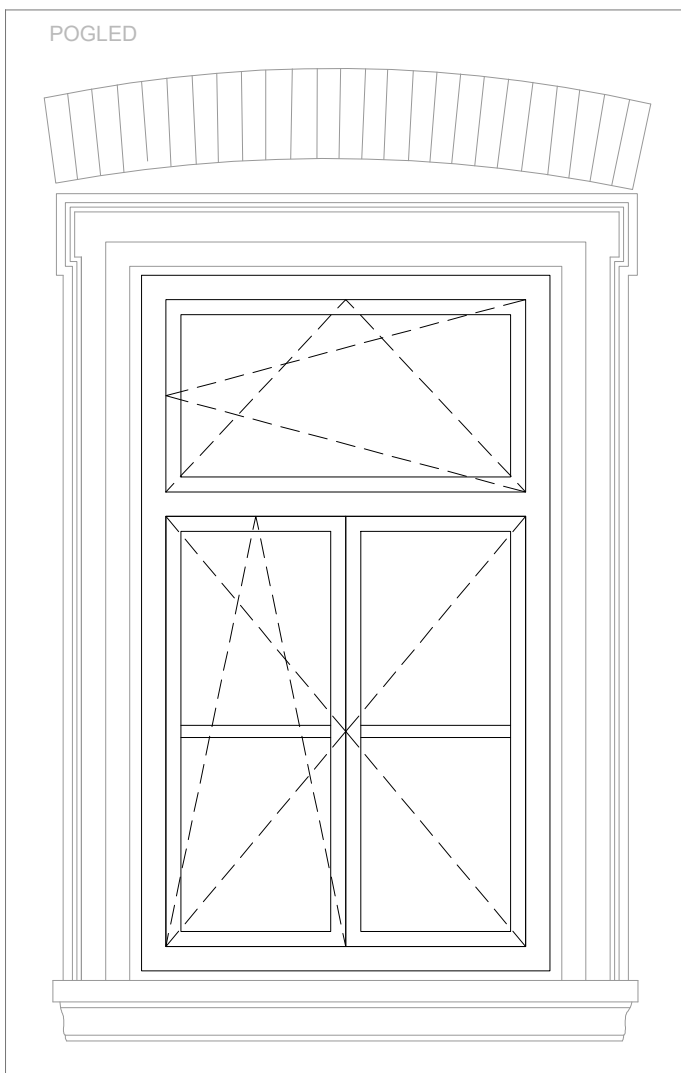

PRESJEK A-A

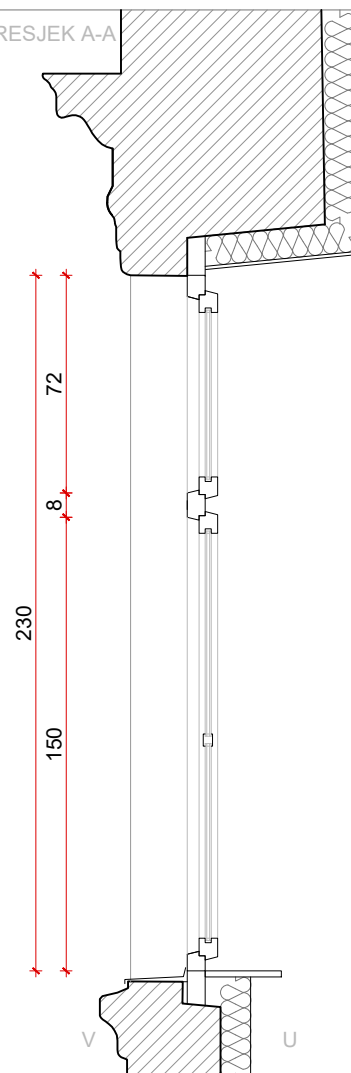

PROARH

Proarh mateković d.o.o.  
za arhitektonsko projektiranje

Kneza Mislava 15, Zagreb, 10000, Croatia  
t. +385 1 46 36 015, +385 1 46 36 002, f. + 385 1 45 52 878

investitor:	Virovitičko-podravaska županija, Trg Ljudevita Patačića 1, 33000 Virovitica OIB: 93362201007	glavni projektant:	Davor Mateković, dipl.ing.arh.	sadržaj:	SHEME STOLARIJE m 1:25
građevina:	Centar za kulturu zdravlja - Rekonstrukcija dvorca Janković u Cabuni	projektant:	Davor Mateković, dipl.ing.arh.	br. t.d.	
lokacija:	k.č.br. 607/2 k.o. Cabuna	suradnici:	Tomislav Stojan, dipl.ing.arh., Nataša Mandir, mag.ing.arch.,	datum:	studen 2020.
faza:	IZVEDBENI PROJEKT	direktor:	Tomislav Stojan, dipl.ing.arh.	list:	

TLOCRT

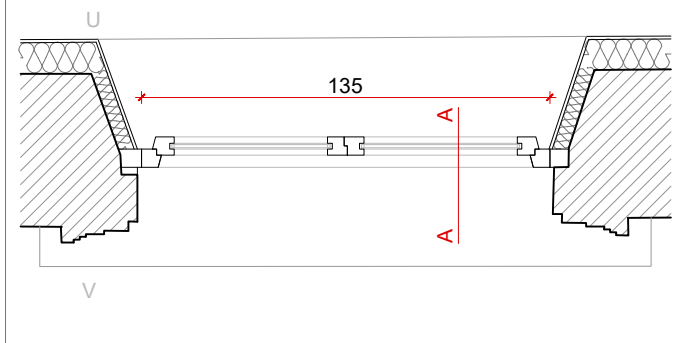

VANJSKA  
STOLARIJA

ST. 20

DVOKRILNI ZAOKRETNO-OTKLOPNI PROZOR S  
ZAOKRETNO-OTKLOPNIM NADSVJETLOM  
UGRADBA U POSTOJEĆI ZID OD OPEKE

135/245 cm

kom: 9

POGLED

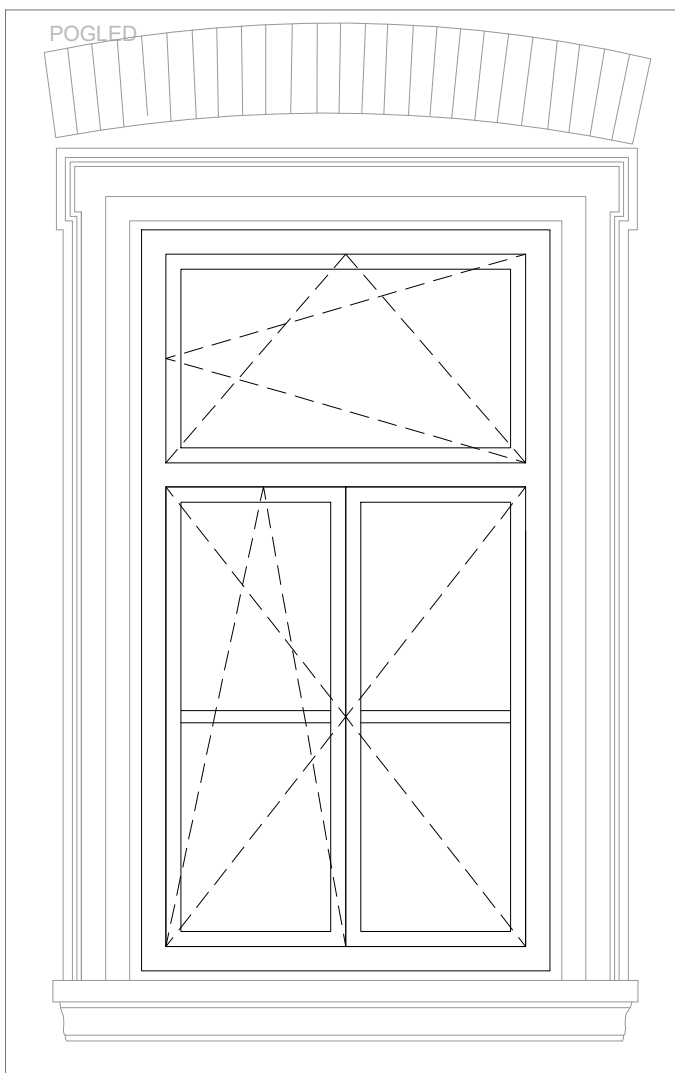

PRESJEK A-A

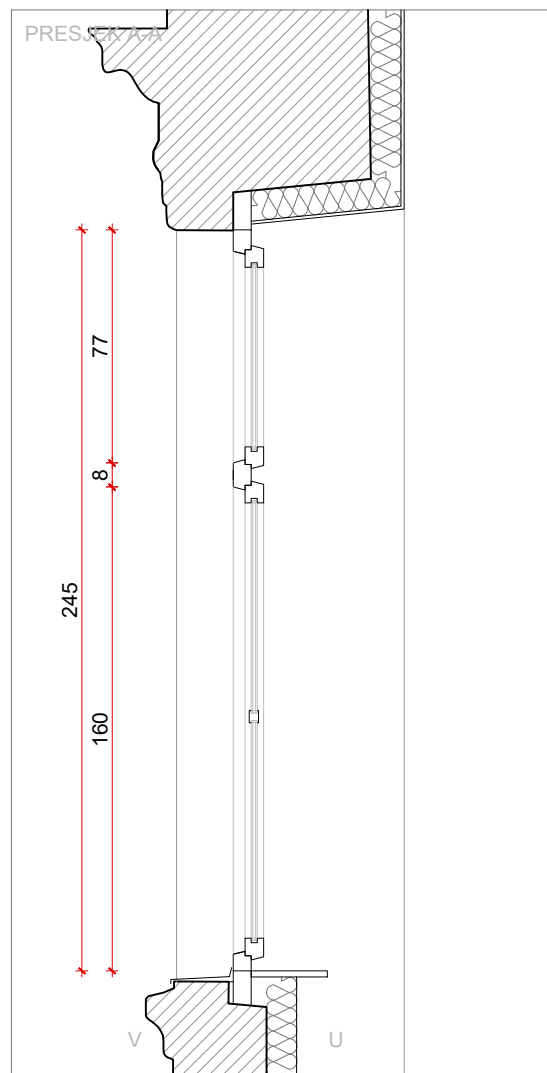

**PROARH**

Proarh mateković d.o.o.  
za arhitektonsko projektiranje

Kneza Mislava 15, Zagreb, 10000, Croatia  
t. +385 1 46 36 015, +385 1 46 36 002, f. + 385 1 45 52 878

investitor: Virovitičko-podravska županija, Trg Ljudevita Patačića 1, 33000 Virovitica OIB: 93362201007	glavni projektant: Davor Mateković, dipl.ing.arh.	sadržaj: <b>SHEME STOLARIJE</b> m 1:25
	projektant: Davor Mateković, dipl.ing.arh.	
građevina: Centar za kulturu zdravlja - Rekonstrukcija dvorca Janković u Cabuni	suradnici: Tomislav Stojan, dipl.ing.arh., Nataša Mandir, mag.ing.arch.,	br. t.d. 07/14
lokacija: k.č.br. 607/2 k.o. Cabuna	direktor: Tomislav Stojan, dipl.ing.arh.	datum: studeni 2020.
faza: <b>IZVEDBENI PROJEKT</b>		list:

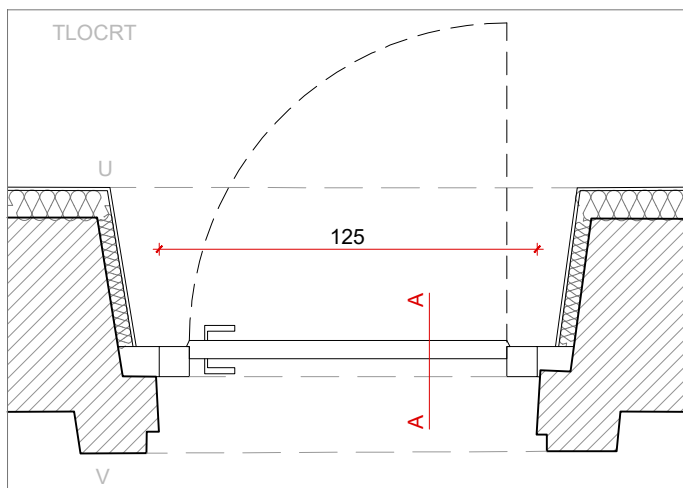

VANJSKA  
STOLARIJA

ST. 21

EVAKUACIJSKA JEDNOKRIČNA ZAOKRETNA  
VRATA S UREDAJEM ZA FIKSIRANJE U STALNO  
OTVORENOM POLOŽAJU

UGRADBA U POSTOJEĆI ZID OD OPEKE

125/245 cm

kom: L= 2  
D= 1

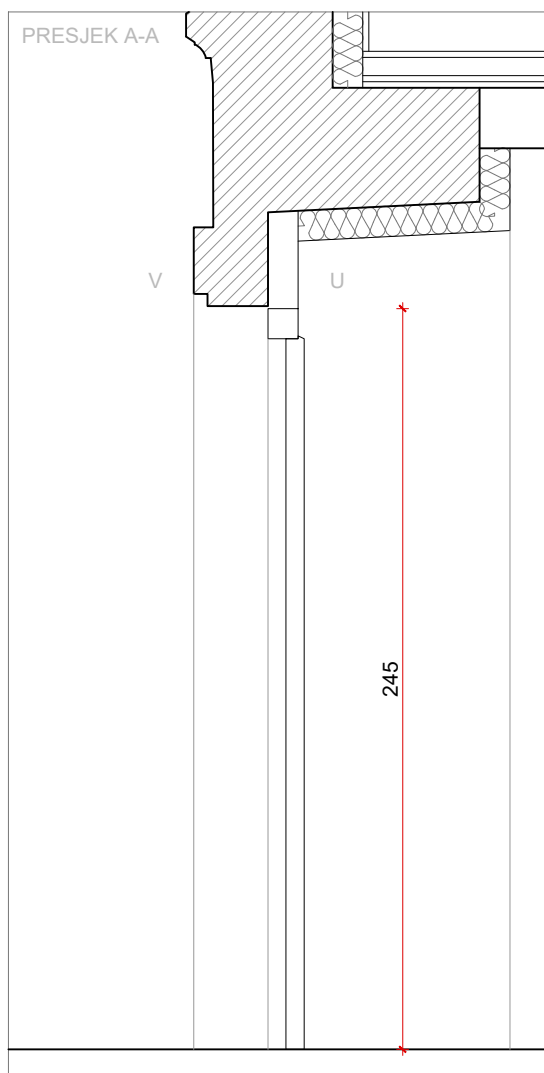
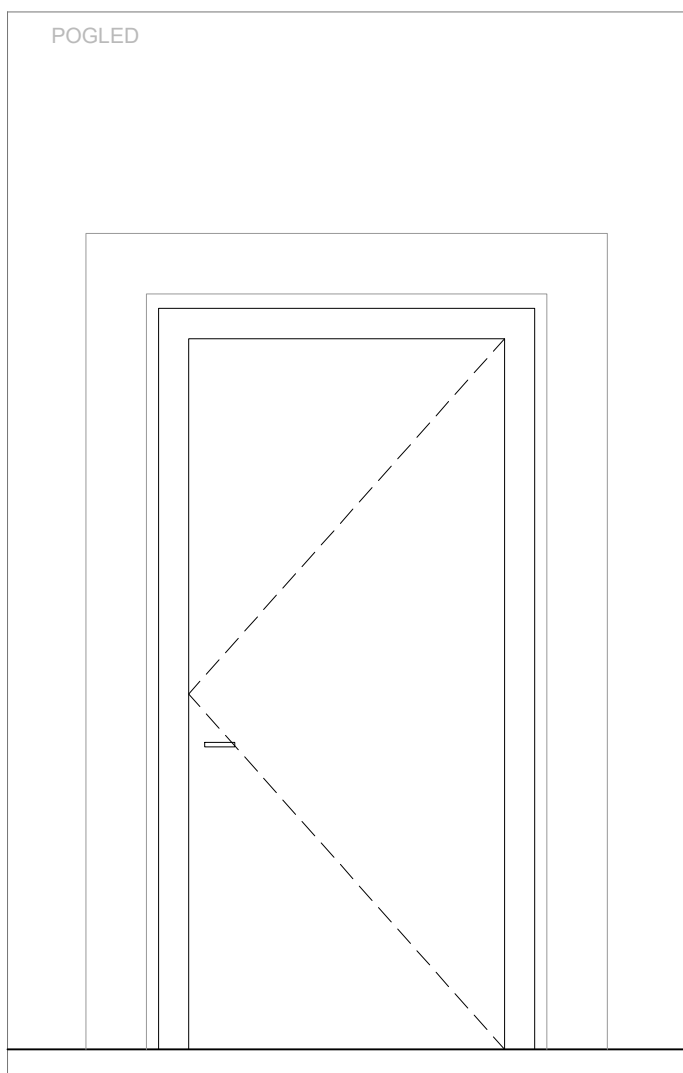

PROARH

Proarh mateković d.o.o.  
za arhitekonsko projektiranje

Kneza Mislava 15, Zagreb, 10000, Croatia  
t. +385 1 46 36 015, +385 1 46 36 002, f. + 385 1 45 52 878

investitor:	Virovitičko-podravka županija, Trg Ljudevita Patačića 1, 33000 Virovitica OIB: 93362201007	glavni projektant:	Davor Mateković, dipl.ing.arh.	sadržaj:	SHEME STOLARIJE m 1:25
građevina:	Centar za kulturu zdravlja - Rekonstrukcija dvorca Janković u Cabuni	projektant:	Davor Mateković, dipl.ing.arh.	br. t.d.	
lokacija:	k.č.br. 607/2 k.o. Cabuna	suradnici:	Tomislav Stojan, dipl.ing.arh., Nataša Mandir, mag.ing.arch.,	datum:	studeni 2020.
faza:	IZVEDBENI PROJEKT	direktor:	Tomislav Stojan, dipl.ing.arh.	list:	

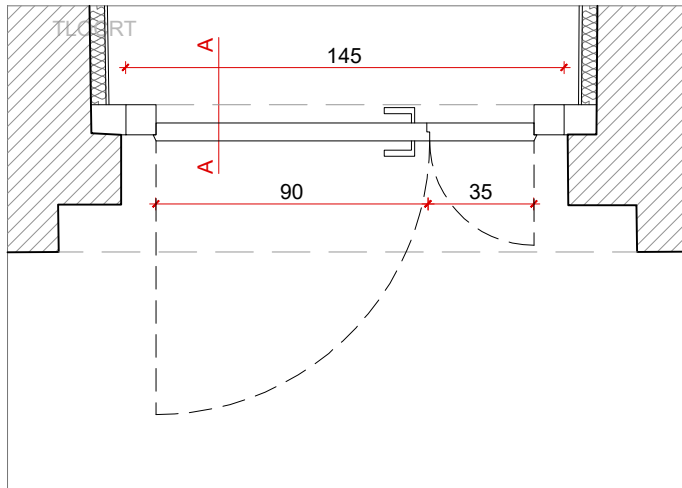

**VANJSKA  
STOLARIJA**

**ST. 22**

EVAKUACIJSKA DVOKRILNA ZAOKRETNA VRATA  
UGRADBA U POSTOJEĆI ZID OD OPEKE

145/280 (220+60) cm

kom: 1

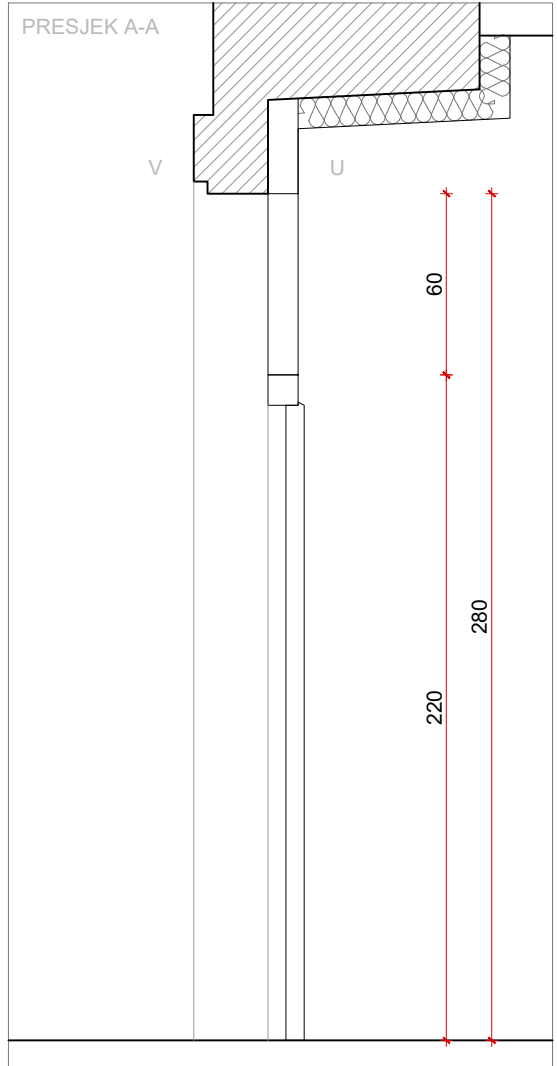
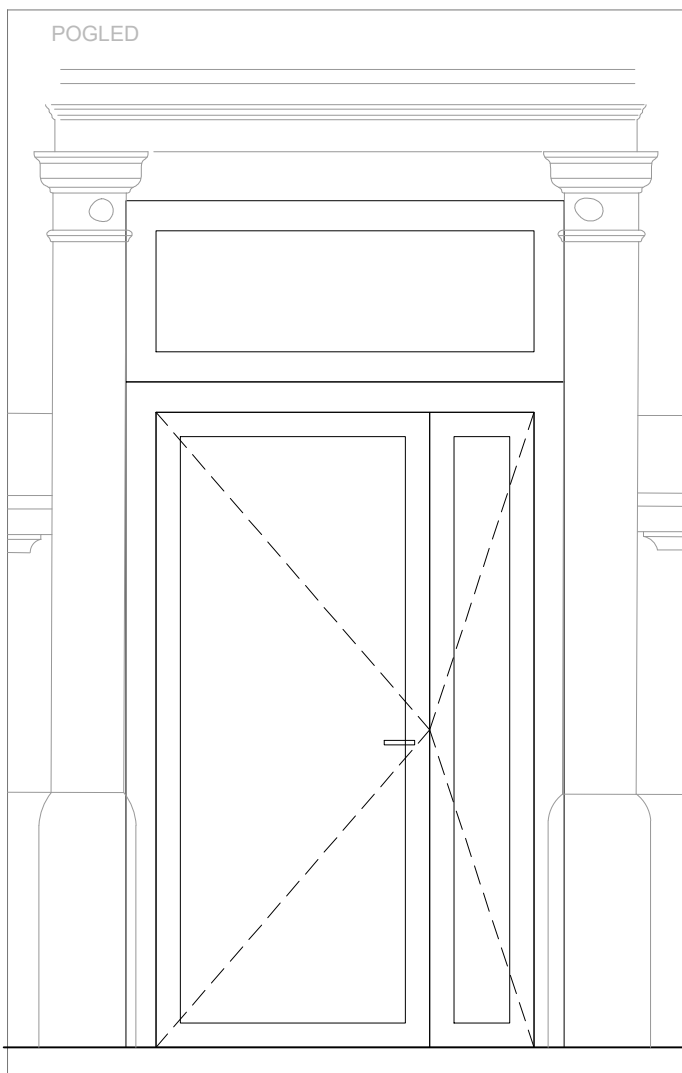

**P R O A R H**

Proarh mateković d.o.o.  
za arhitektonsko projektiranje

Kneza Mislava 15, Zagreb, 10000, Croatia  
t. +385 1 46 36 015, +385 1 46 36 002, f. + 385 1 45 52 878

investitor:	Virovitičko-podravska županija, Trg Ljudevita Patačića 1, 33000 Virovitica OIB: 93362201007	glavni projektant:	Davor Mateković, dipl.ing.arh.	sadržaj:	<b>SHEME STOLARIJE m 1:25</b>
građevina:	Centar za kulturu zdravlja - Rekonstrukcija dvorca Janković u Cabuni	projektant:	Davor Mateković, dipl.ing.arh.	br. t.d.	07/14
lokacija:	k.č.br. 607/2 k.o. Cabuna	suradnici:	Tomislav Stojan, dipl.ing.arh., Nataša Mandir, mag.ing.arch.,	datum:	studeni 2020.
faza:	<b>IZVEDBENI PROJEKT</b>	direktor:	Tomislav Stojan, dipl.ing.arh.	list:	

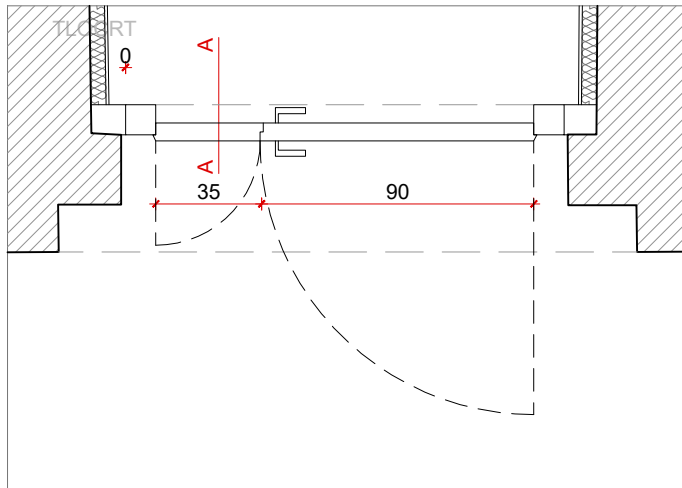

**VANJSKA  
STOLARIJA**

**ST. 23**

EVAKUACIJSKA DVOKRILNA ZAOKRETNA VRATA S  
UREĐAJEM ZA FIKSIRANJE U STALNO OTVORENOM  
POLOŽAJU

UGRADBA U POSTOJEĆI ZID OD OPEKE

145/280 (220+60) cm

kom: 1

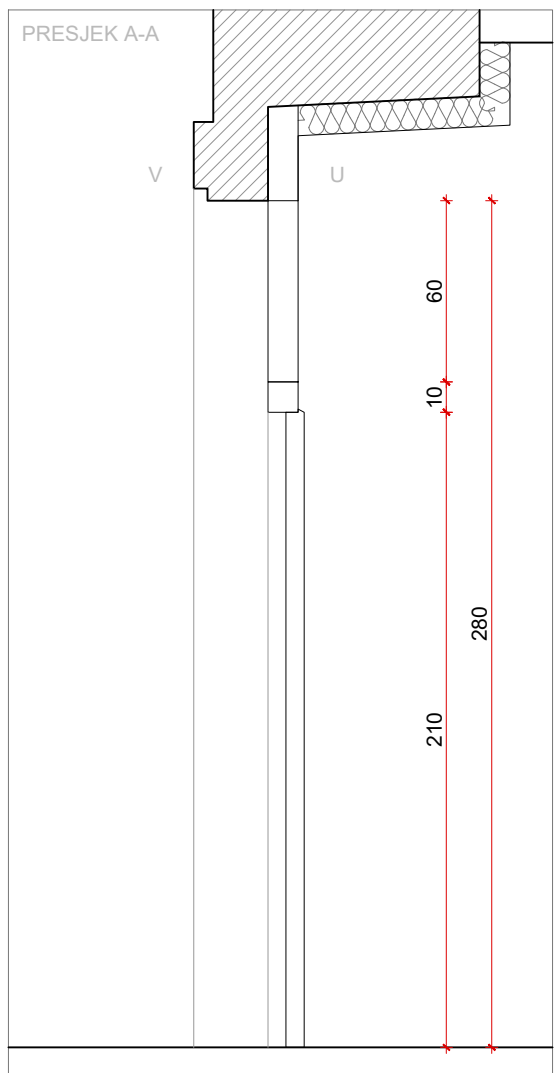
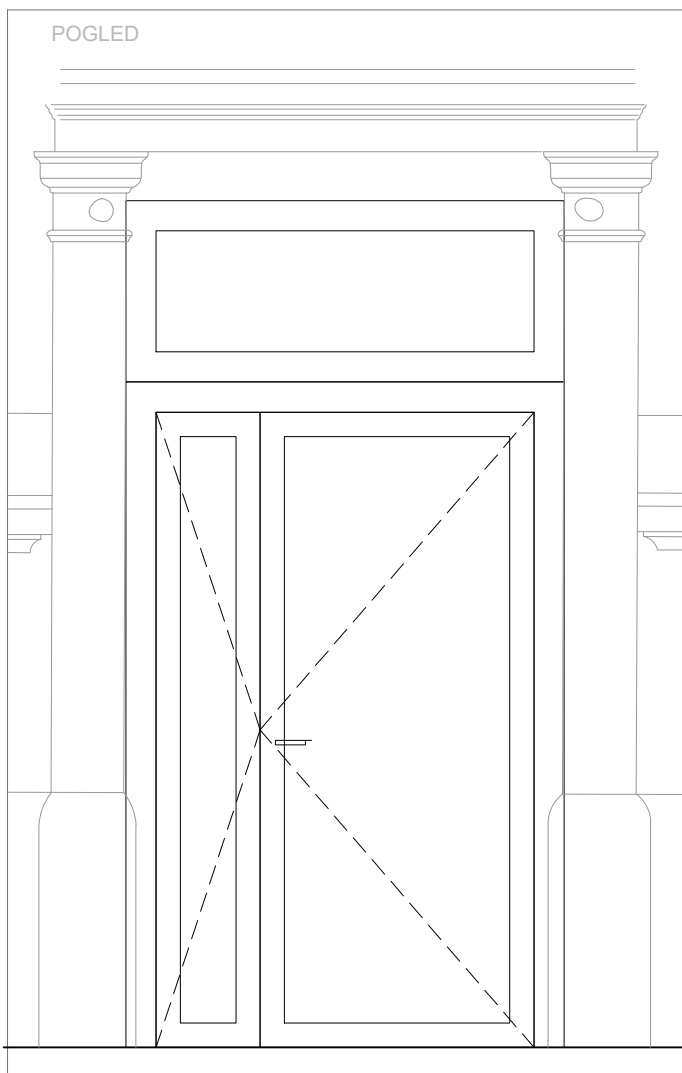

**PROARH**

Proarh mateković d.o.o.  
za arhitektonsko projektiranje

Kneza Mislava 15, Zagreb, 10000, Croatia  
t. +385 1 46 36 015, +385 1 46 36 002, f. + 385 1 45 52 878

investitor:	Virovitičko-podravaska županija, Trg Ljudevita Patačića 1, 33000 Virovitica OIB: 93362201007	glavni projektant:	Davor Mateković, dipl.ing.arh.	sadržaj:	<b>SHEME STOLARIJE</b> m 1:25
građevina:	Centar za kulturu zdravlja - Rekonstrukcija dvorca Janković u Cabuni	projektant:	Davor Mateković, dipl.ing.arh.	br. t.d.	07/14
lokacija:	k.č.br. 607/2 k.o. Cabuna	suradnici:	Tomislav Stojan, dipl.ing.arh., Nataša Mandir, mag.ing.arch.,	datum:	studeni 2020.
faza:	<b>IZVEDBENI PROJEKT</b>	direktor:	Tomislav Stojan, dipl.ing.arh.	list:	

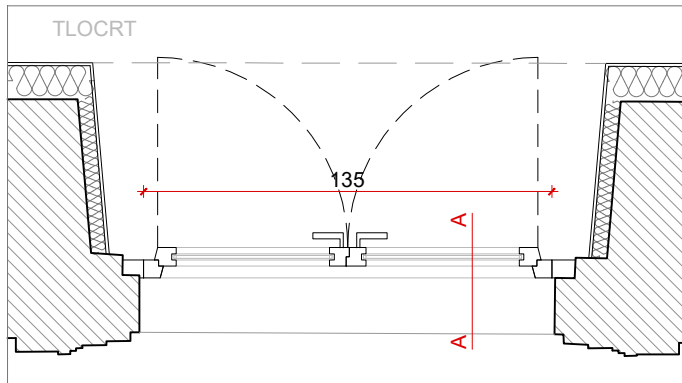

**VANJSKA  
STOLARIJA**

**ST. 24**

EVAKUACIJSKA DVOKRILNA OSTAKLJENA  
ZAKRETNA VRATA S OTKLOPNIM NADSVJETLOM  
UGRADBA U POSTOJEĆI ZID OD OPEKE

135/340 (255+85) cm

kom: 1

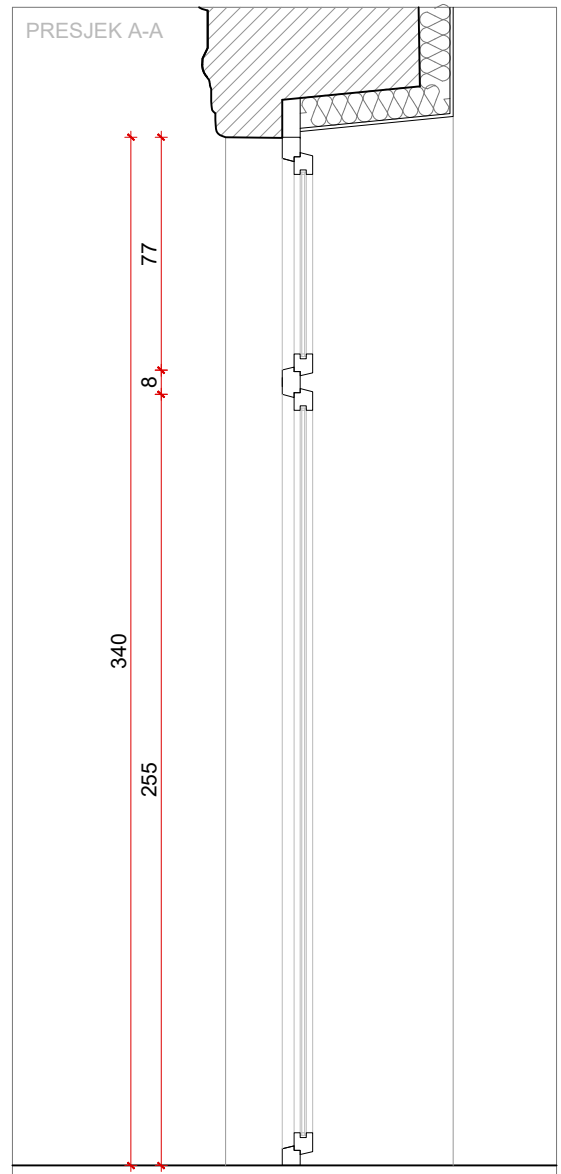
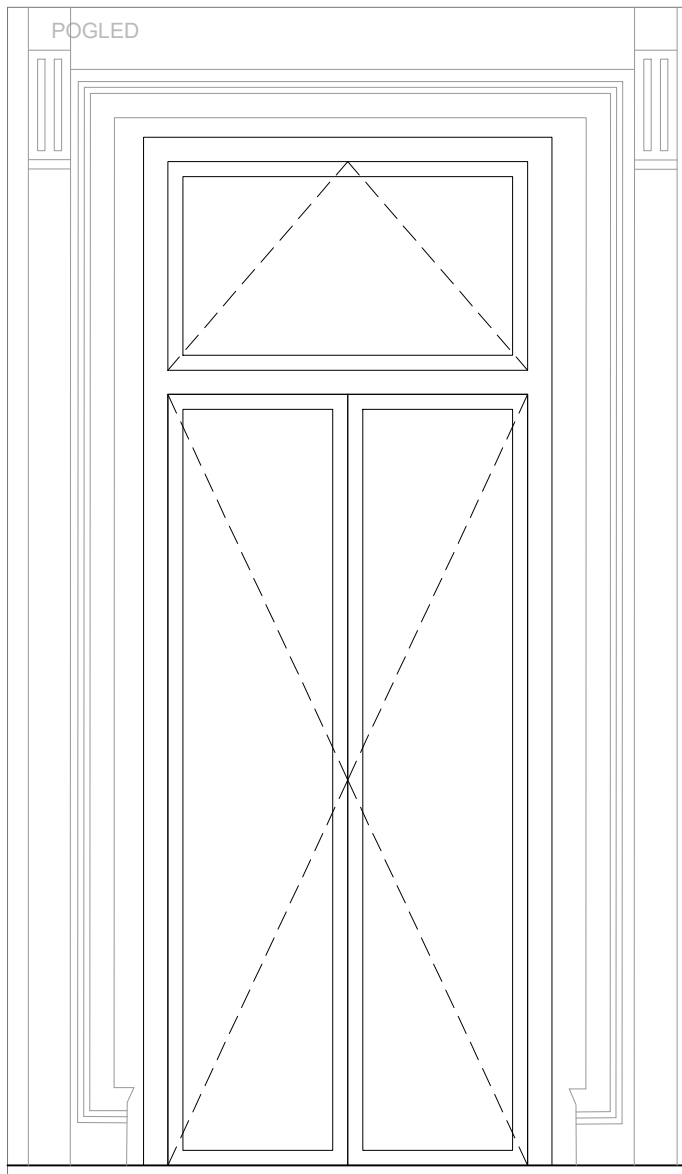

**PROARH**

Proarh mateković d.o.o.  
za arhitektonsko projektiranje

Kneza Mislava 15, Zagreb, 10000, Croatia  
t. +385 1 46 36 015, +385 1 46 36 002, f. + 385 1 45 52 878

investitor:	Virovitičko-podravska županija, Trg Ljudevita Patačića 1, 33000 Virovitica OIB: 93362201007	glavni projektant:	Davor Mateković, dipl.ing.arh.	sadržaj:	<b>SHEME STOLARIJE</b> m 1:25
građevina:	Centar za kulturu zdravlja - Rekonstrukcija dvorca Janković u Cabuni	projektant:	Davor Mateković, dipl.ing.arh.	br. t.d.	07/14
lokacija:	k.č.br. 607/2 k.o. Cabuna	suradnici:	Tomislav Stojan, dipl.ing.arh., Nataša Mandir, mag.ing.arch.,	datum:	studeni 2020.
faza:	<b>IZVEDBENI PROJEKT</b>	direktor:	Tomislav Stojan, dipl.ing.arh.	list:	



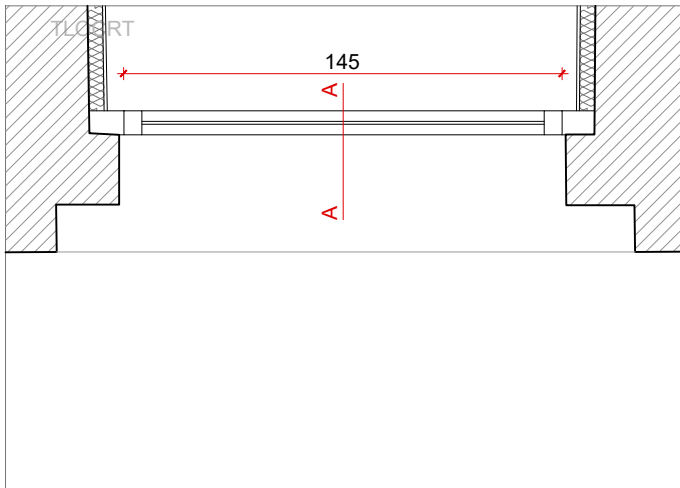

VANJSKA  
STOLARIJA

ST. 25

POLUKRUŽNO FIKSNO NADSVJETLO

145/73 cm

kom: 1

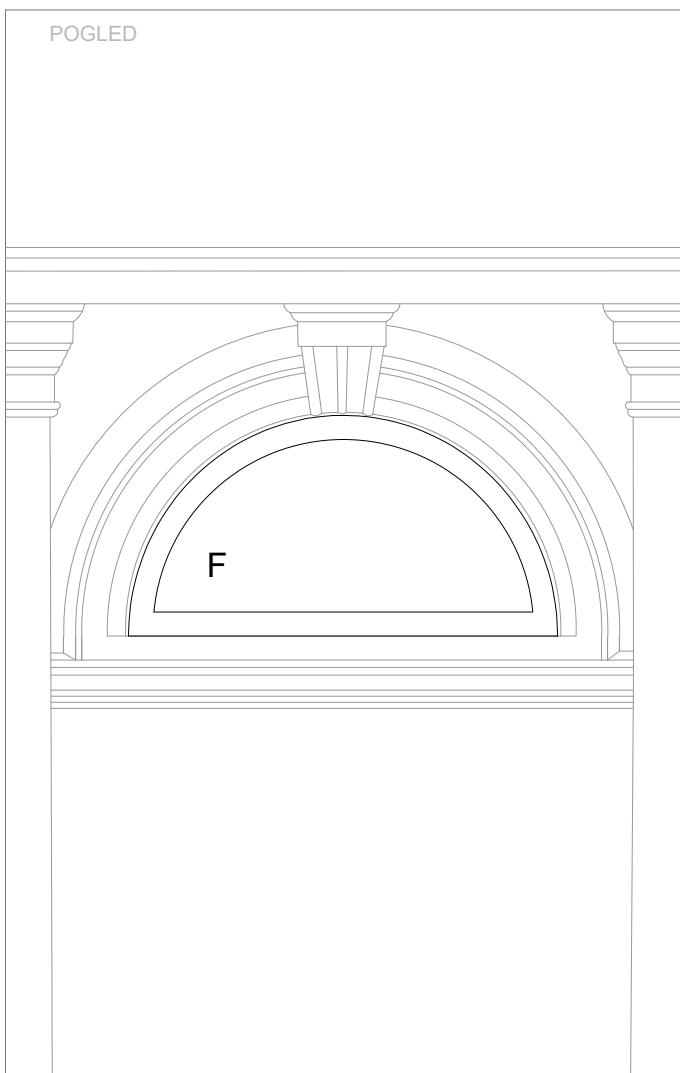

PRESJEK A-A

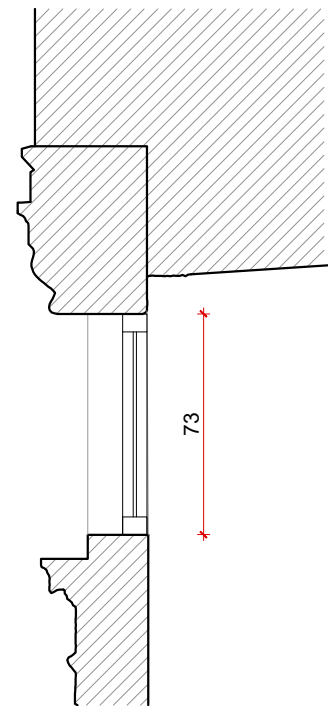

PROARH

Proarh mateković d.o.o.  
za arhitektonsko projektiranje

Kneza Mislava 15, Zagreb, 10000, Croatia  
t. +385 1 46 36 015, +385 1 46 36 002, f. + 385 1 45 52 878

investitor:	Virovitičko-podravaska županija, Trg Ljudevita Patačića 1, 33000 Virovitica OIB: 93362201007	glavni projektant:	Davor Mateković, dipl.ing.arh.	sadržaj:	SHEME STOLARIJE m 1:25
		projektant:	Davor Mateković, dipl.ing.arh.		
građevina:	Centar za kulturu zdravlja - Rekonstrukcija dvorca Janković u Cabuni	suradnici:	Tomislav Stojan, dipl.ing.arh., Nataša Mandir, mag.ing.arch.,	br. t.d.	07/14
lokacija:	k.č.br. 607/2 k.o. Cabuna			datum:	studen 2020.
faza:	IZVEDBENI PROJEKT	direktor:	Tomislav Stojan, dipl.ing.arh.	list:	

TLOCRT

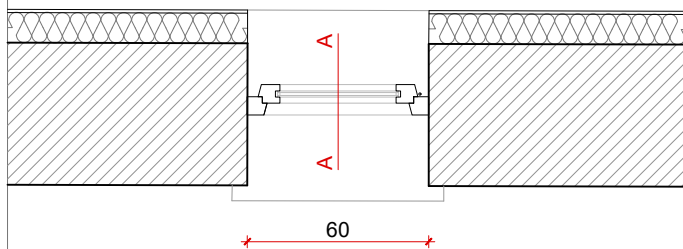

VANJSKA  
STOLARIJA

ST. 26

KRUŽNI ZAOKRETNI PROZOR

60/60 cm

kom: 2

POGLED

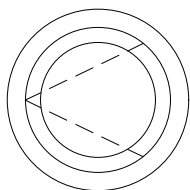

PRESJEK A-A

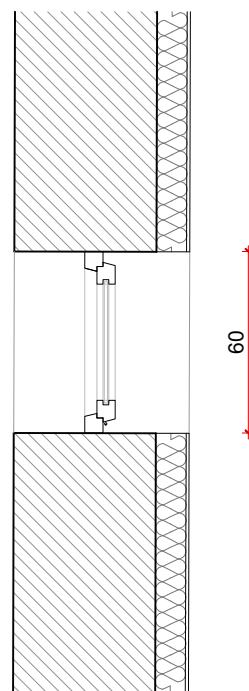

Proarh mateković d.o.o.  
za arhitektonsko projektiranje

Kneza Mislava 15, Zagreb, 10000, Croatia  
t. +385 1 46 36 015, +385 1 46 36 002, f. + 385 1 45 52 878

investitor: Virovitičko-podravka županija, Trg Ljudevita Patačića 1, 33000 Virovitica OIB: 93362201007	glavni projektant: Davor Mateković, dipl.ing.arh.	sadržaj: <b>SHEME STOLARIJE</b> m 1:25
	projektant: Davor Mateković, dipl.ing.arh.	
građevina: Centar za kulturu zdravlja - Rekonstrukcija dvorca Janković u Cabuni	suradnici: Tomislav Stojan, dipl.ing.arh., Nataša Mandir, mag.ing.arch.,	br. t.d. 07/14
lokacija: k.č.br. 607/2 k.o. Cabuna		datum: studeni 2020.
faza: <b>IZVEDBENI PROJEKT</b>	direktor: Tomislav Stojan, dipl.ing.arh.	list:

TLOCRT

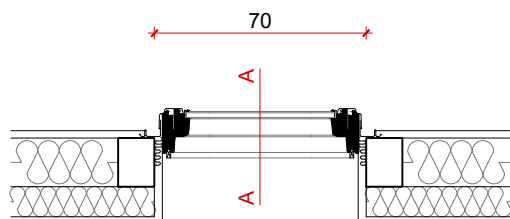

VANJSKA  
STOLARIJA

ST. 27

KROVNI PROZOR TIPa VELUX  
UGRADBA NA DRVENO KROVIŠTE

70/135 cm kom: 39

POGLED

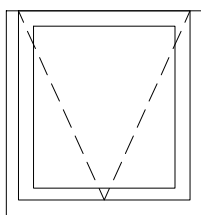

PRESJEK A-A

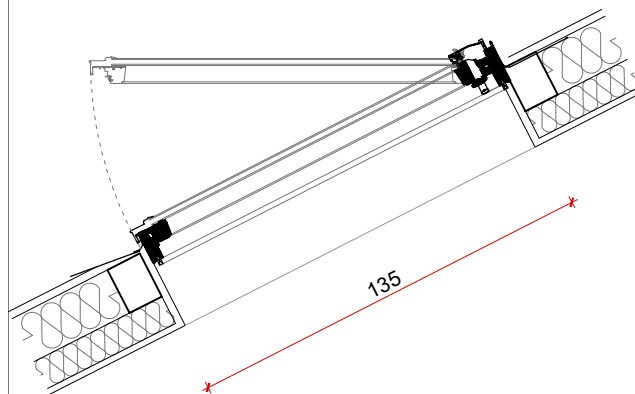

Proarh mateković d.o.o.  
za arhitektonsko projektiranje

Kneza Mislava 15, Zagreb, 10000, Croatia  
t. +385 1 46 36 015, +385 1 46 36 002, f. + 385 1 45 52 878

investitor:	Virovitičko-podravaska županija, Trg Ljudevita Patačića 1, 33000 Virovitica OIB: 93362201007	glavni projektant:	Davor Mateković, dipl.ing.arh.	sadržaj: SHEME STOLARIJE m 1:25
		projektant:	Davor Mateković, dipl.ing.arh.	
građevina:	Centar za kulturu zdravlja - Rekonstrukcija dvorca Janković u Cabuni	suradnici:	Tomislav Stojan, dipl.ing.arh., Nataša Mandir, mag.ing.arch.,	br. t.d. 07/14
lokacija:	k.č.br. 607/2 k.o. Cabuna			datum: studeni 2020.
faza:	IZVEDBENI PROJEKT	direktor:	Tomislav Stojan, dipl.ing.arh.	list: